



RENCO USA, INC.
5959 Blue Lagoon Dr., STE. 301
Miami, FL 33126
www.renco-usa.com
(833) 23R-ENCO

**RENCo MINERAL COMPOSITE FIBER
 REINFORCED (MCFR) BUILDING
 SYSTEM**

CSI Section:

**06 71 00 Structural Composite Shapes and
 Plates**

1.0 RECOGNITION

RENCo Mineral Composite Fiber Reinforced (MCFR) Building System has been evaluated for interior and exterior, unreinforced load-bearing or nonload-bearing walls and shear walls, floors, and roofs. The structural performance, physical characteristics, and fire resistance properties of the RENCo MCFR Building System were evaluated for compliance with the following codes:

- 2021, 2018, 2015, and 2012 International Building Code® (IBC)
- 2021, 2018, 2015, and 2012 International Residential Code® (IRC)
- 2023 and 2020 Florida Building Code, Building – Supplement attached
- 2023 and 2020 Florida Building Code, Residential – Supplement attached

2.0 LIMITATIONS

Use of the RENCo MCFR Building System recognized in this report is subject to the following limitations:

2.1 RENCo MCFR Building System structures shall be designed and installed in accordance with this report and the applicable code.

2.2 The manufacturer’s published installation manual and this report shall be available at all times at the jobsite during construction. Where there is a conflict, the more restrictive shall govern.

2.3 Plans, specifications, engineering calculations, and other construction documents specifying the use of the RENCo MCFR Building System shall be prepared by a registered design professional where required by the statutes of the jurisdiction in which the project is to be constructed and submitted to the building official for approval.

2.4 Use of RENCo MCFR Building System as a seismic lateral force-resisting system in Seismic Design Categories C, D, E, and F is outside the scope of this report. Use of shear values noted in Section 3.2.4 of this report are limited to load-bearing and non-load bearing walls in Seismic Design Categories A and B.

2.5 RENCo MCFR components recognized in this report are produced in Saruhanli, Manisa, Turkey.

3.0 PRODUCT USE

3.1 General: The RENCo MCFR Building System recognized in this report consists of RENCo MCFR wall units, floor and roof joists, bridging and decking installed and erected with RENCo Adhesives and fasteners to construct structural walls, floors, and roofs for interior and exterior, unreinforced load-bearing or nonload-bearing walls and shear walls, floors, and roofs.

3.2 Design:

3.2.1 Walls and Shear Walls

3.2.1.1 Gravity Load: The maximum allowable axial compression gravity load for walls with floor-to-floor wall heights less than or equal to 10 feet (3.05 m) shall be 4,669 plf (6,950 kg/m).

3.2.1.2 Out-of-Plane Load: The maximum allowable out-of-plane (wind) load for the RENCo MCFR Building System, exclusive of the EIFS finish, for walls with floor-to-floor wall heights less than or equal to 10 feet (3.05 m) shall be 94 psf (4.5 kPa), at a deflection limit of L/240.

3.2.1.3 EIFS Out-of-Plane Load: The maximum allowable out-of-plane (wind) load for the Master Wall® Aggre-flex EIFS coatings for walls with floor-to-floor wall heights less than or equal to 10 feet (3.05 m) shall be 74 psf (3.55kPa). Master Wall® Aggre-flex EIFS shall be installed in accordance with Section 3.4 of this report.

3.2.1.4 Shear Load: The maximum allowable shear load for non-load bearing walls shall be 553 pounds/foot (823 kg/m) with a corresponding deflection limit of L/240. The maximum aspect ratio is 1:1.

3.2.1.5 Uplift Load: The maximum allowable uplift (axial tension) load shall be 1,730 lb/ft (2,575 kg/m).

3.2.1.6 Fastener Load: The maximum allowable fastener loads for use in the RENCo MCFR wall system shall be in accordance with Table 1 of this report.

The product described in this Uniform Evaluation Service (UES) Report has been evaluated as an alternative material, design or method of construction in order to satisfy and comply with the intent of the provision of the code, as noted in this report, and for at least equivalence to that prescribed in the code in quality, strength, effectiveness, fire resistance, durability and safety, as applicable, in accordance with IBC Section 104.11. This document shall only be reproduced in its entirety.





3.2.1.7 Combined Loads: Walls shall be designed using load combinations in accordance with Sections 1605.1 or 1605.2 of the 2021 IBC or Section 1605.3 of the 2018, 2015, and 2012 IBC, as applicable. For cases where the loads interact, the sum total of ratios each applied load to corresponding allowable load given in this report shall be no greater than 1.0.

3.2.2 Floors and Roofs

3.2.2.1 Joists: The maximum allowable gravity load for joists with a clear span less than or equal to 14 feet-6 inches (4.42 m) shall be 237 plf (352.69 kg/m) at a deflection limit of L/360.

3.2.2.2 Decking: The maximum allowable gravity load for deck with a clear span less than or equal to 24 inches (610 mm) shall be 142 psf (6.8 kPa) for 4.5 inch and 8-inch decking at a deflection limit of L/360.

3.2.2.3 Diaphragm Shear Load: The maximum allowable shear strength of the diaphragm is 66 lb/ft with a shear stiffness of 2358 lb/in when the load is applied parallel to floor joist and 71 plf (105 kg/m) with a shear stiffness of 7,046 lb/in when the load is applied perpendicular to the floor joist. The floor assembly shall be: floor joists are supported by the pocket beam blocks and located at approximately 24" o.c. The floor decking shall be attached to the floor joists using ¼" – 14 x 1" long DP3 Concealor pancake head self-drilling screws. Floor decking, when added, shall always span perpendicular to the floor joists. MCFR Bridging shall be located between floor joist and spaced at third points along the length of the joists. MCFR Bridging shall be attached to the sides of the floor joist using (4) ¼" x 14 x 1" long DP3 Concealor pancake head, self-drilling screws. One fastener shall be located at the top and bottom on each side of the flange of the bridging. The ends and the outer sides of the perimeter flooring shall be supported on extended wall ledgers which is integral to the perimeter middle row wall block. There shall be ¼-14 x 1" long DP3 Concealor pancake head self-drilling deck fasteners at the perimeter (3 fasteners every 16" o.c.). On the underside of the floor joists, No. 22 gauge steel hat channels shall be attached to the underside of each joist using (2) #10 x 1" long, HWH self-drilling fasteners. One layer of 5/8" Type X Gypsum Ceiling Board shall be attached to the hats using #6 x 1 5/8" long drywall screws. Drywall screws shall be located at 8" o.c. around perimeter and 12" o.c. in the field.

3.2.2.4 Roof Uplift Load: The maximum allowable roof uplift (tension) load for an assembly consisting of ¼ inch (3.2 mm) thick by 2 3/8 inch wide by 13 3/4 inch high RENCo Purlins spaced at 24 inches on center with 20 1/2 inch wide by 1 5/8 inch high RENCo roof decking shall be 50 psf (244 kg/sm). Purlins shall be attached to the structure using three 5/16"-18 x 3-inch-long hex head bolts with 1 inch

diameter washer and nuts. Decking shall be attached to purlins using ¼" – 14 x 3-inch-long self-drilling pancake head screws spaced at 5 inches on center through the deck and into the purlins. The capacity and design of the supporting members for the purlins are the responsibility of the structural designer, and subject to the approval of the building official.

3.2.2.5 Deck Attachment Fastener Loads: The maximum allowable fastener loads for use in the RENCo MCFR Building System to attach decking shall be in accordance with Table 1 of this report.

TABLE 1 -- ALLOWABLE LOAD PER FASTENER*			
Fastener	Allowable Load Fastener Withdrawal lbs (kg)	Allowable Load Pull Through lbs (kg)	Allowable Load Lateral Resistance lbs (kg)
Concealor	133 (60.3) #14-14-DP3	187 (84.8) #14-14-DP3	273 (123.8) #14-14-DP3

*Allowable Loads are based on a minimum Safety Factor of 5.
SI: 1 lbf = 4.448 N, 1 inch = 25.4 mm

3.2.2.6 Combined Loads: Floors and roofs shall be designed using the ASD load combinations in accordance with Sections 1605.1 or 1605.2 of the 2021 IBC or Section 1605.3 of the 2018, 2015, and 2012 IBC, as applicable. For cases where the loads interact, the sum total of ratios of each applied load to corresponding allowable load given in this report shall be no greater than 1.0.

3.3 Installation: The RENCo MCFR Building System published installation instructions and this report shall be strictly adhered to and a copy of the instructions shall be available at all times on the jobsite during installation. Where there is a conflict, the more restrictive shall govern. Additionally, drawings and/or specifications shall supplement the published instructions, and feature detailed information concerning how the RENCo MCFR wall units, joists, and decking described in this report are to be integrated into the building under construction.

Exterior walls and roof decking exposed to weather and/or outside moisture shall have a code-complying water-resistive barrier installed in such a manner to provide a continuous barricade behind the protective covering. The exterior surface of exterior walls of RENCo MCFR walls shall be covered with Master Wall® Aggre-Flex Class PB EIFS as described in IAPMO UES ER-433. Interior walls shall be covered with minimum ½ inch (12.7 mm) thick gypsum wallboard, complying with ASTM C1396. Gypsum wallboard shall be fastened to RENCo MCFR wall with #6-by-1¼-inch-long (31.8 mm) self-drilling, bugle head screws spaced 8 inches (203 mm) on center around the wall board perimeter and



12 inches (305 mm) on center in the field of the board. The RENCo MCFR wall units used in wall construction are laid with horizontal and vertical joints filled with RENCo Adhesive, described in Section 4.3 of this report. The tongue-and-groove block system, however, does not require the vertical joints to have adhesive. RENCo Adhesive shall be mixed and applied according to the RENCo USA, Inc. published installation instructions. Adhesive in the interior slots shall be applied to a minimum nominal depth of $\frac{9}{16}$ inches (15 mm) high and to within $\frac{1}{2}$ inch (12 mm) of each outside edge of the block (Figure 2 of this report). The RENCo MCFR walls shall be laid in running bond pattern, with the vertical joints staggered a minimum of 4 inches (102 mm).

The RENCo MCFR floor and roof joists shall be installed in specified beam pockets with two vertical full height beads of RENCo Adhesive applied on each face of the beam pocket.

REnCo Adhesive shall be applied to clean surfaces using the manufacturer's specific application equipment and procedures as set forth in the published installation instructions and this report. The ambient temperature range during adhesive installation shall be 40°F (4°C) to 100°F.

REnCo MCFR bridging shall be mechanically fastened to MCFR joists at each corner using four $\frac{1}{4}$ " x 14 x 1-inch long DP3 Concealer pancake head self-drilling screws.

REnCo MCFR decking shall be mechanically fastened to MCFR joists and perimeter ledger block using one fastener located at every decking recess / joist intersection and no less than 3 fasteners every 16 inches around the non-recessed perimeter of the deck using $\frac{1}{4}$ " x 14 x 1-inch long DP3 Concealer pancake head self-drilling screws.

3.4 Master Wall® Aggre-flex EIFS: The exterior surface of exterior walls of RENCo MCFR walls shall be covered with Master Wall® Aggre-Flex Class PB EIFS as described in IAPMO UES ER-433, except that 3.4 lb/yd² (1.8 kg/m²) self-furring expanded metal lath complying with ASTM C847, shall be installed over the WRB and fastened to the RENCo MCFR walls with #8 x $\frac{1}{4}$ -inch-long (31.8 mm) washer head screws spaced 12-inches (305 mm) on-center.

4.0 PRODUCT DESCRIPTION

4.1 RENCo Mineral Composite Fiber Reinforced Wall Units: RENCo MCFR wall units are proprietary building units, factory-manufactured in a Sheet Molding Compound compression molding process involving mineral calcite, glass fiber reinforcement and additives. The wall units are designed to interlock vertically when stacked on top of each other by incorporating a protrusion on the top surface into a recess on the bottom surface of the next block and including male to female channel type connections on the sides of components

to allow for mechanical interconnection. The components typically include starter units, line units, caps, plugs and fenestration opening channel.

4.2 RENCo Mineral Composite Fiber Reinforced Joists, Bridging and Decking: RENCo MCFR joists, bridging and decking are proprietary structural shapes, factory-manufactured in a pultrusion process involving mineral calcite, glass fiber reinforcement and additives. The joists are designed to be adhesively joined into wall assemblies. The bridging and decking are designed to be mechanically fastened to the joists and surrounding wall assemblies. Bridging shall be located such that the joist span between bridging or surrounding wall assembly is no greater than 5 feet on center.

4.3 RENCo Adhesive: RENCo Adhesive [Plexus MA530 Adhesive manufactured by ITW Polymers] consists of a two-part proprietary methacrylate adhesive available in tubes, 5-gallon (18.9 L) buckets, 50-gallon (189 L) barrels or totes, with a proprietary mixing nozzle and application equipment available from RENCo, USA to control mix ratio and application. RENCo Adhesive shall be used with RENCo MCFR wall units as recognized in this report. The RENCo Adhesive, when stored in unopened containers and protected from moisture, has a 6-month shelf life from the date of manufacture and can be applied when the temperature is between 40°F and 100°F.

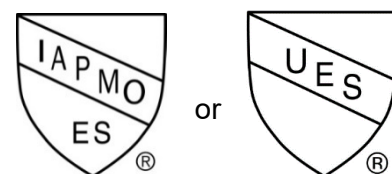
4.4 Fire Resistance Rated Assemblies: The assemblies summarized in Table 2 of this report comply with IBC Section 703.2 as fire-resistance-rated wall, floor, and roof assemblies.

5.0 IDENTIFICATION

REnCo Mineral Composite Fiber Reinforced (MCFR) wall units, joists, bridging, and decking are identified by labels which shall include the manufacturer's name (REnCo), the IAPMO Uniform ES Evaluation Report Number (ER-508), and a numeric code indicating the production plant and date of production. Labels may be located on pallets.

REnCo Adhesive is identified by labeling which shall include the manufacturer's name (ITW Polymers' Plexus MA530 Adhesive), and mixing and application instructions.

Either IAPMO UES Mark of Conformity may also be used as shown below:



IAPMO UES ER-508



6.0 SUBSTANTIATING DATA

Data in accordance with IAPMO UES EC-30, Evaluation Criteria for Mineral Composite Fiber Reinforced (MCFR) Building Systems, editorially revised July 2021.

6.1 Reports of surface burning characteristics of building materials in accordance with ASTM E84.

6.2 Reports of fire tests for evaluating contribution of wall and ceiling interior finish to room fire growth in accordance with NFPA 286.

6.3 Reports of fire tests of building construction and materials in accordance with ASTM E119.

6.4 Reports of mechanical fasteners in plastic lumber and shapes in accordance with ASTM D6117

6.5 Reports of strength tests of wall assemblies in accordance with ASTM E72.

6.6 Reports of structural performance by uniform static air pressure difference in accordance with ASTM E330.

6.7 Reports of static load test for shear resistance in accordance with ASTM E564.

6.8 Reports of strength of anchors in concrete elements in accordance with ASTM E488.

6.9 Reports of density of smoke in accordance with ASTM D2843

6.10 Reports of static load testing of framed roof or roof diaphragm in accordance with ASTM E455.

6.11 Reports of flexural properties in accordance with ASTM D6109.

6.12 Reports of determination of ignition temperature in accordance with ASTM D1929.

6.13 Reports of determination of rate of burn in accordance with ASTM D635.

6.14 Test reports are from laboratories in compliance with ISO/IEC 17025.

6.15 Manufacturer's descriptive literature and installation instructions.

7.0 STATEMENT OF RECOGNITION

This evaluation report describes the results of research completed by IAPMO Uniform Evaluation Service on RENCo Mineral Composite Fiber Reinforced components to assess their conformance to the codes shown in Section 1.0 of this report and documents the product's certification.

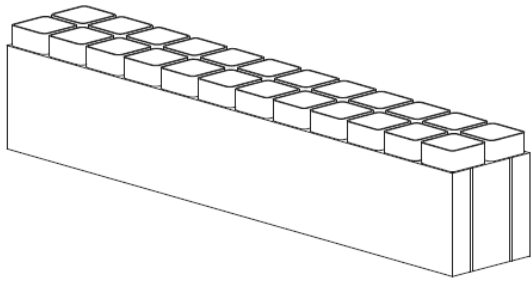
RENCO USA, Inc. MCFR components are produced at locations noted in Section 2.5 of this report under a quality control program with periodic inspections under the supervision of IAPMO UES.

For additional information about this evaluation report please visit www.uniform-es.org or email at info@uniform-es.org

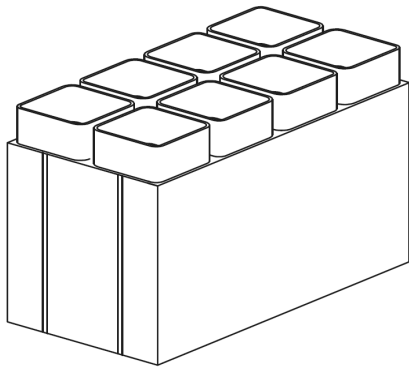


TABLE 2 – FIRE-RESISTANCE-RATED ASSEMBLIES

Item	Rating	Construction	Allowable Axial Load
1	2-Hour Rated Exterior Walls	<p>7.87-inch (20 mm) wide RENCo MCFR modular wall units stacked in a running bond pattern with each course adhered to the lower course with Plexus MA530 adhesive in accordance with Sections 3.3 and 4.2 of this report. Interior face has two layers of ⁵/₈-inch (16 mm) thick Type X gypsum wallboard applied vertically attached with 6d x 1¹/₄-inch (31.7 mm) bugle-head screws at 12-inches (305 mm) on-center (o.c.) around the perimeter and in the field. The outside face has two layers of ⁵/₈-inch (16 mm) thick Type X exterior gypsum sheathing board applied vertically or horizontally, attached using 6d x 1¹/₄-inch (31.7 mm) bugle-head screws at 12-inches (305 mm) o.c. around the perimeter and in the field. Screw heads and joints of wallboard shall be taped and treated with joint compound in accordance with IBC Section 2508, and either ASTM C840 or GA-216.</p> <p>The water-resistive barrier and EIFS shall comply with Section 4.0 of this report and applied as described in Section 3.3 of this report.</p>	4,133 plf
2	1-Hour Rated Exterior Walls	<p>7.87-inch (20 mm) wide RENCo MCFR modular wall units stacked in a running bond pattern with each course adhered to the lower course with Plexus MA530 adhesive in accordance with Sections 3.3 and 4.2 of this report. Interior face has one layer of ⁵/₈-inch (16 mm) thick Type X gypsum wallboard applied vertically attached with 6d x 1¹/₄-inch (31.7 mm) bugle-head screws at 12-inches (305 mm) on-center (o.c.) around the perimeter and in the field. The outside face has one layer of ⁵/₈-inch (16 mm) thick Type X exterior gypsum sheathing board applied vertically or horizontally, attached using 6d x 1¹/₄-inch (31.7 mm) bugle-head screws at 12-inches (305 mm) o.c. around the perimeter and in the field. Screw heads and joints of wallboard shall be taped and treated with joint compound in accordance with IBC Section 2508, and either ASTM C840 or GA-216.</p> <p>The water-resistive barrier and EIFS shall comply with Section 4.0 of this report and applied as described in Section 3.3 of this report.</p>	4,133 plf
3	1-Hour Rated Floor or Roof	<p>13³/₄ inch x 2³/₈-inch RENCo MCFR floor and roof joist spaced at 24 inches on-center adhesively connected to and spanning 7³/₄ thick MCFR Wall assemblies with 1¹/₂ inch high RENCo MCFR Deck mechanically fastened as specified in Section 3.3 of this Report. Two layers of ⁵/₈ inch thick Type X gypsum wallboard applied to ⁷/₈-inch galvanized steel hat channel using #6 x 1¹/₄ inch long bugle head self-drilling screws spaced at 12 inches on-center. The hat channel shall be spaced at 16 inches on-center and shall be applied to the bottom chord of MCFR Joists with #10 x 16 x 1-inch-long pancake head self-drilling screws. Screw heads and joints of wallboard shall be taped and treated with joint compound in accordance with IBC Section 2508, and either ASTM C840 or GA-216.</p>	60 psf



Standard 48" Unit



Standard 16" Unit

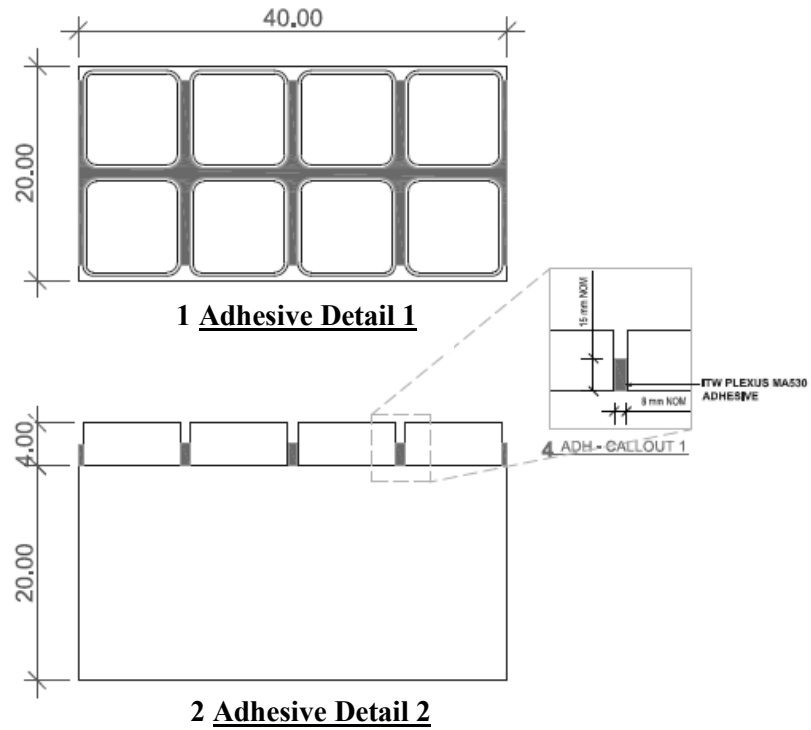


FIGURE 2 – Adhesive Placement

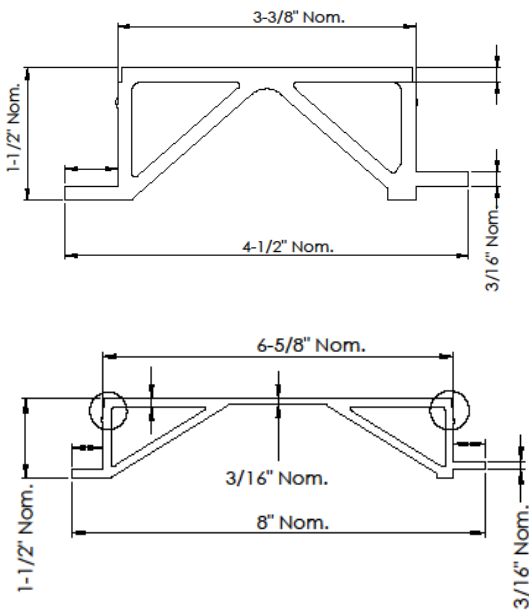


FIGURE 1 – Decking Standard Units

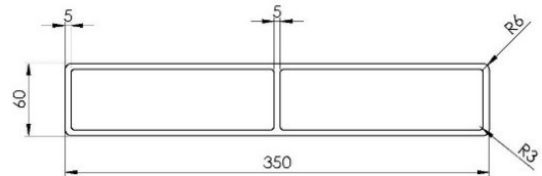


FIGURE 3 – Beam detail

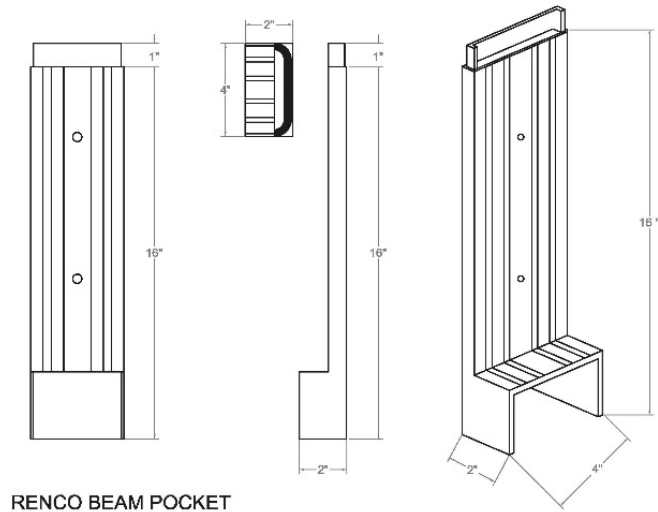


FIGURE 4 – Beam Pocket

RENCO DECK LEDGER BLOCK 10"

W= 10" Nom.(25 cm)
 L = 8" Nom.(20 cm)
 H = 8" Nom.(20 cm)

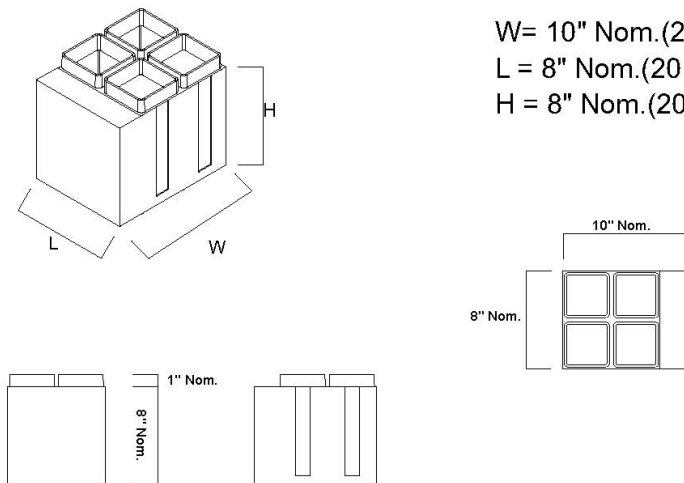


FIGURE 5 – Renco Ledger Block



FLORIDA SUPPLEMENT

RENCO USA, INC.
5959 Blue Lagoon Dr., STE. 301
Miami, FL 33126
www.renco-usa.com
833.23R.ENCO

RENCO MINERAL COMPOSITE FIBER REINFORCED (MCFR) BUILDING SYSTEM

CSI Section:

06 71 00 Structural Composite Shapes and Plates

1.0 RECOGNITION

The RENCo Mineral Composite Fiber Reinforced (MCFR) Building System evaluated in IAPMO UES Evaluation Report ER-508 is a satisfactory alternative to the following codes and regulations:

- 2023 and 2020 Florida Building Code, Building (FBC, Building)
- 2023 and 2020 Florida Building Code, Residential (FBC, Residential)

2.0 LIMITATIONS

Use of the RENCo MCFR Building System recognized in this supplement is subject to the requirements in ER-508 and the following additional limitations:

2.1 Verification shall be provided that a quality assurance agency audits the manufacturer's quality assurance program and audits the production quality of products, in accordance with Section (5)(d) of Florida Rule 61G20-3.008. The quality assurance agency shall be approved by the Commission (or building official when the report holder does not possess an approval by the Commission).

2.2 Evaluation to the High-Velocity Hurricane Zone provisions in Section 1512 of the FBC, Building, for roofing assemblies is beyond the scope of this report.

2.3 For use in High-Velocity Hurricane Zones (HVHZ), the RENCo MCFR Building System used in wall applications has been evaluated in accordance with Sections 1625 and 1626 of the FBC, Building.

2.3.1 TAS 201-94: The tested assembly consisted of 16-inch (406.4 mm) and 48-inch (1219.2 mm) standard RENCo MCFR units adhered with RENCo Adhesive (Plexus MA530 Adhesive manufactured by ITW polymers). The

assembly complies with the large missile impact requirements of TAS 201.

2.3.2 TAS 202-94: The tested assembly consisted of 16-inch (406.4 mm) and 48-inch (1219.2 mm) standard RENCo MCFR units adhered with RENCo Adhesive (Plexus MA530 Adhesive manufactured by ITW polymers) and was 4 feet (1219.2 mm) wide by 10 feet (3048 mm) tall. The system complies with TAS 202 testing requirements for uniform static air pressure with a negative and positive design pressure of 143 psf (6.8 kPa). The maximum recorded deflection of the assembly when tested to 142 psf (6.8 kPa) is 0.56 inch (14 mm) with a permanent set of 0.06 inch (1.5 mm).

2.3.3 TAS 203-94: The tested assembly consisted of 16-inch (406.4 mm) and 48-inch (1219.2 mm) standard RENCo MCFR units adhered with RENCo Adhesive (Plexus MA530 Adhesive manufactured by ITW polymers) and was 4 feet (1219.2 mm) wide by 10 feet (3048 mm) tall. The system complies to the TAS 203 testing requirements for cyclic wind pressure loading resistance with a negative and positive design pressure of 55 psf (2.63 kPa). The maximum average recorded deflections and permanent set of the assembly, when tested to the 55 psf (2.63 kPa) design pressure, is 0.28 inch (7 mm) and 0.02 inch (0.5 mm), respectively, meeting the 90 percent recovery requirements of the standard.

2.4 This supplement expires concurrently with ER-508.

3.0 PRODUCT USE

The design and installation of the RENCo Mineral Composite Fiber Reinforced (MCFR) Building System shall be in accordance with the 2021 or 2018 International Building Code, as applicable, and as noted in ER-508.

4.0 SUBSTANTIATING DATA

4.1 Testing Application Standard (TAS) No. 201-94 – Impact Test Procedures -Large Missile.

4.2 Testing Application Standard (TAS) No. 202-94 – Criteria for Testing Impact and Non-Impact Resistant Building Envelope Components Using Static Air Pressure.

4.3 Testing Application Standard (TAS) No. 203-94 – Criteria for Testing Products Subject to Cyclic Wind Pressure Loading

4.4 Test reports are from laboratories in compliance with ISO/IEC 17025.

For additional information about this evaluation report please visit www.uniform-es.org or email at info@uniform-es.org