



ALLEGHENY STRUCTURAL COMPONENTS, INC.

3778 Oneida Valley Road
Emlenton, Pennsylvania 16373
(724) 867-1100

AlleghenyStructural.com

OPEN JOIST 2000® WOOD TRUSSES

CSI Sections:

- 06 11 00 Wood Framing
- 06 11 13 Engineered Wood Products
- 06 17 00 Shop Fabricated Structural Wood
- 06 17 53 Shop-Fabricated Wood Trusses

1.0 RECOGNITION

Allegheny Structural Components, Inc., Open Joist 2000® Wood Trusses have been evaluated for use as joists in floor and roof assemblies. The trusses have been evaluated for structural performance. The Open Joist 2000® trusses described in this report are recognized as alternatives to the framing prescribed in the following codes and regulations:

- 2021, 2018, 2015, and 2012 International Building Code® (IBC)
- 2021, 2018, 2015, and 2012 International Residential Code® (IRC)
- 2023 Florida Building Code - Building (FBC, Building) – Supplement Attached
- 2023 Florida Building Code - Residential (FBC, Residential) – Supplement Attached

Open Joist 2000® Wood Trusses complies with the requirements for wood trusses in IBC Section 2303.4 and IRC Sections R502.11 and R802.10.

2.0 LIMITATIONS

Use of Open Joist 2000® Wood Trusses recognized in this report is subject to the following limitations:

2.1 Use of the Open Joist 2000® Wood Trusses shall comply with the provisions of the applicable codes, the manufacturer’s published installation instructions, and this report. Where conflicts occur in these provisions, the most restrictive shall govern.

2.2 Designs and details for building assemblies incorporating Open Joist 2000® Wood Trusses shall be submitted to the building official for approval.

2.3 Open Joist 2000® Wood Trusses shall not be cut, notched, spliced, or otherwise altered except as specifically allowed by this report, the manufacturer’s published installation

instructions, or as approved by the registered design professional. Broken or damaged trusses shall not be used.

2.4 Open Joist 2000® Wood Trusses and connections shall not be exposed to wet service conditions in use.

2.5 Open Joist 2000® Wood Trusses have not been evaluated for use with fire-retardant treated wood or in fire-resistance rated assemblies under the scope of this report.

2.6 Use of the trusses as part of the lateral load resisting system has not been evaluated.

2.7 The trusses recognized in this report are produced by Allegheny Structural Components, Inc. in Emlenton, PA.

3.0 PRODUCT USE

3.1 Design: The appropriate trusses for the project shall be chosen using the allowable uniform live load tables in this report corresponding to the design dead load, maximum deflection criteria, joist span, joist depth, and joist spacing. The tables are for use with joists in a simple-span support configuration. A joist depth and on-center spacing shall be chosen from the tables that corresponds to the design live load to provide adequate support capacity for the design loading. The design tables provide maximum allowable uniform live loads for three or more members installed parallel, with top chord sheathing installed.

The trusses shall be designed to meet or exceed minimum ASD loading requirements specified in the applicable building code. Selection of the floor trusses for structural loading and its supporting structure shall be designed by an approved design professional. The registered design professional shall prepare calculations and drawings when required by the statutes of the jurisdiction in which the project is to be constructed.

3.2 Installation:

Open Joist 2000® Wood Trusses shall be installed in accordance with the manufacturer’s published installation instructions and design drawings required by Section 2303.4.1.1 of the IBC, or Sections R502.11.4 or R802.10.1 of the IRC, as applicable. The trusses shall be fastened to the sill or wall plates and anchorage shall be provided as required by the IBC or IRC. When fastening Open Joist 2000® Wood Trusses, care shall be taken to avoid splitting wooden truss members. Strong backs, gussets, and bearing blocks shall be provided for bracing, cantilever, and point load bearing as required by the truss design. Any required strong back bridging shall be installed prior to floor sheathing. When using joist hangers, the hanger manufacturers’ nailing instructions shall be followed.

The product described in this Uniform Evaluation Service (UES) Report has been evaluated as an alternative material, design or method of construction in order to satisfy and comply with the intent of the provision of the code, as noted in this report, and for at least equivalence to that prescribed in the code in quality, strength, effectiveness, fire resistance, durability and safety, as applicable, in accordance with IBC Section 104.11. This document shall only be reproduced in its entirety.



UNIFORM EVALUATION SERVICES



ACCREDITED PRODUCT CERTIFICATION BODY



The trusses shall be covered with minimum $5/8$ -inch-thick (15.9 mm) sheathing installed according to IBC or IRC using fasteners and adhesive. Minimum bearing length shall be $1\frac{1}{2}$ inches (38.1 mm) unless noted otherwise in the truss designs or manufacturer’s instructions. Draft stopping and fire blocking shall be installed in accordance with the IBC or IRC.

4.0 PRODUCT DESCRIPTION

Open Joist 2000® Wood Trusses are engineered wood joists with dimension lumber flanges, diagonal and vertical web members, and trimmable ends. The members are joined using glued finger-joined connections. The lumber used to manufacture the trusses is kiln-dried to a moisture content of 19 percent or less before processing.

The trusses are non-destructively machine-load-tested in accordance with the Open Joist 2000® quality control procedures to verify their ability to support the allowable loads indicated in this report.

Open Joist 2000® Wood Trusses are available in lengths up to 32 feet (9.8 m), and in nominal joist depths of $9\frac{3}{8}$, $11\frac{1}{4}$, $11\frac{7}{8}$, 13, 14, 16, 18, and 20 inches (238, 286, 302, 330, 356, 406, 457, and 508 mm, respectively). See tables for lengths for each model.

4.1 Chords: The top and bottom flange members of the trusses are nominally 2-by-3 or 2-by-4 lumber oriented flatwise and grooved to receive the web members. The finger-jointed chords are grade-marked No.2 SPF, MSR 2100, or MSR 2400 lumber depending on the joist depth and model.

4.2 Webs: The diagonal web members are nominally 2-by solid lumber optimally sized to handle the panel design loads, and oriented upright to fit into the grooves in the flanges. Vertical webs are installed at each end and at the edges of mechanical chases. The webs are joined to the chords and to each other with glued finger-joinery.

4.3 Trimmable-Ends: The vertical webs at the ends of each truss are solid sawn lumber designed to be trimmed to the proper joist length where necessary as shown in Figure 1 of this report.

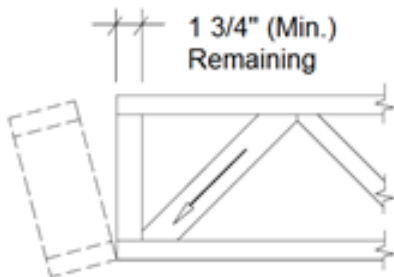
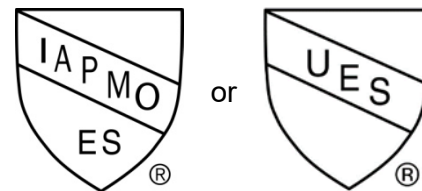

FIGURE 1 - ALLOWABLE TRUSS END TRIM

4.4 Adhesive: The adhesive used to glue the chord end joints and the finger-joined node connections is water-proof resorcinol resin meeting ASTM D2559 and ASTM D7247 for performance at elevated temperatures.

5.0 IDENTIFICATION

Open Joist 2000® Wood Trusses are identified by the manufacturer’s name (Allegheny Structural Components) and phone number, the Open Joist 2000® trademark, the product model number, the date of manufacture, and evaluation report number (ER-501). Either IAPMO Uniform Evaluation Service Mark of Conformity may also be used as follows:



IAPMO UES ER-501

6.0 SUBSTANTIATING DATA

6.1 Data in accordance with the ICC-ES Acceptance Criteria for Prefabricated Parallel Chord Wood Trusses (AC224).

6.2 Manufacturer’s descriptive literature and installation instructions.

6.3 Test reports are from laboratories in compliance with ISO/IEC 17025.

7.0 STATEMENT OF RECOGNITION

This evaluation report describes the results of research completed by IAPMO Uniform Evaluation Service on Open Joist 2000® Wood Trusses to assess their conformance to the codes shown in Section 1.0 of this report and documents the product’s certification. The wood trusses are produced at locations noted in Section 2.7 of this report under a quality control program with periodic inspection under the supervision of IAPMO UES.

For additional information about this evaluation report please visit www.uniform-es.org or email at info@uniform-es.org



TABLE 1A (15DL-L/360) - ALLOWABLE UNIFORM FLOOR LIVE LOADS (psf)

Joist Clear Span	15 LB. DEAD LOAD - L/360 LIVE LOAD DEFLECTION															
	9 ¹ / ₄ " & 9 ³ / ₈ " Depth				11 ¹ / ₄ " Depth				11 ⁷ / ₈ " Depth				13" & 14" Depth			
	O.C. Spacing				O.C. Spacing				O.C. Spacing				O.C. Spacing			
	12"	16"	19.2"	24"	12"	16"	19.2"	24"	12"	16"	19.2"	24"	12"	16"	19.2"	24"
10'-1"	183	134	109	84	187	136	112	87	212	155	127	99	241	177	145	113
11'-1"	147	110	92	73	165	121	99	77	188	137	112	87	212	155	127	99
12'-1"	115	86	72	58	144	105	85	66	164	119	97	75	188	137	112	87
13'-1"	94	71	59	47	128	92	75	57	145	105	85	65	169	123	100	77
14'-1"	77	58	48	38	106	79	66	50	120	90	75	57	137	99	80	61
15'-1"	64	48	40	32	90	68	56	43	102	77	64	49	128	93	75	57
16'-1"	86	65	54	43	77	58	48	38	88	66	55	43	105	75	60	45
17'-1"	72	54	45	36	85	61	48	36	91	65	51	38	90	64	51	38
18'-1"	61	46	38	30	74	52	41	31	84	59	47	35	99	71	56	42
19'-1"	53	40	33	26	82	62	51	38	92	65	52	39	88	62	49	37
20'-1"					69	52	43	34	78	59	49	38	80	56	44	33
21'-1"					59	44	37	30	67	50	42	34	83	62	51	38
22'-1"									59	44	37	30	74	56	44	33
23'-1"													64	48	40	29
24'-1"													58	43	36	29

Joist Clear Span	15 LB. DEAD LOAD - L/360 LIVE LOAD DEFLECTION											
	16" Depth				18" Depth				20" Depth			
	O.C. Spacing				O.C. Spacing				O.C. Spacing			
	12"	16"	19.2"	24"	12"	16"	19.2"	24"	12"	16"	19.2"	24"
10'-1"	241	177	145	113	347	259	215	171	341	256	213	171
11'-1"	212	155	127	99	318	237	196	156	313	235	196	156
12'-1"	188	137	112	87	293	218	181	144	289	217	180	144
13'-1"	169	123	100	77	271	202	167	133	268	201	168	134
14'-1"	153	111	90	69	253	188	156	124	250	188	156	125
15'-1"	145	105	85	65	237	176	146	116	235	176	147	117
16'-1"	142	103	83	63	222	165	137	108	221	166	138	110
17'-1"	169	123	100	77	210	156	129	102	209	156	130	104
18'-1"	161	117	95	73	198	147	122	96	198	148	123	99
19'-1"	128	92	74	57	188	140	116	91	188	141	117	94
20'-1"	148	107	87	67	179	133	110	87	179	134	112	89
21'-1"	121	87	70	53	171	127	105	82	171	128	107	85
22'-1"	127	91	74	56	137	103	85	68	142	105	87	68
23'-1"	104	78	65	52	131	98	82	65	136	101	83	65
24'-1"	96	72	60	47	126	94	79	62	130	96	79	62
25'-1"	83	62	52	42	121	91	76	60	125	92	76	60
26'-1"	83	62	52	42	109	81	66	52	111	82	67	53
27'-1"	75	56	47	38	105	78	64	50	107	78	64	50
28'-1"	64	48	40	32	101	75	61	48	103	76	62	49
29'-1"	56	42	35	28	77	58	48	38	99	73	60	47
30'-1"					75	56	47	37	72	53	43	33
31'-1"									70	51	41	32

For S.I.: 1 inch = 25.4 mm; 1 lbf = 4.4 N; 1 psf = 47.9 Pa

- 1) Table is based on repetitive member use installed in a floor or roof system with minimum 5/8-inch-thick sheathing attached to the top flanges.
- 2) No increase for repetitive member use or duration of load allowed.
- 3) Allowable load values in the table shall be reduced if repetitive member conditions are not achieved (20 percent for 3x2 and 13 percent for 4x2).
- 4) Loads noted in the table are limited by live load deflection and total load deflection as noted in the table.
- 5) Manufactured length refers to overall length that includes the possibility of a 5 1/2-inch bearing on both ends. To calculate the allowable "clear span" subtract 11 inches from the tabulated manufactured length.



TABLE 1B (25DL-L/360) - ALLOWABLE UNIFORM FLOOR LIVE LOADS (psf)																
Joist Clear Span	25 LB. DEAD LOAD - L/360 LIVE LOAD DEFLECTION															
	9 ¹ / ₄ " & 9 ³ / ₈ " Depth				11 ¹ / ₄ " Depth				11 ⁷ / ₈ " Depth				13" & 14" Depth			
	O.C. Spacing				O.C. Spacing				O.C. Spacing				O.C. Spacing			
	12"	16"	19.2"	24"	12"	16"	19.2"	24"	12"	16"	19.2"	24"	12"	16"	19.2"	24"
10'-1"	173	124	99	74	178	128	103	78	202	145	117	89	231	167	135	103
11'-1"	147	107	85	63	157	112	90	68	178	127	102	77	202	145	117	89
12'-1"	115	86	72	55	136	96	77	57	154	109	87	65	178	127	102	77
13'-1"	94	71	59	45	119	84	66	48	135	95	75	55	159	113	90	67
14'-1"	77	58	48	37	105	73	57	41	119	83	65	47	127	89	70	51
15'-1"	64	48	40	31	90	62	48	34	102	71	55	39	119	83	65	47
16'-1"	86	65	50	35	77	54	41	29	88	61	47	33	95	65	50	35
17'-1"	72	54	45	36	77	52	40	27	81	55	41	28	80	54	41	28
18'-1"	61	46	37	25	65	43	33	22	74	49	37	25	89	61	46	32
19'-1"	53	40	33	23	81	55	42	29	82	55	42	29	78	52	39	27
20'-1"					69	48	37	26	78	55	41	28	70	46	34	23
21'-1"					59	43	33	22	67	49	37	25	80	54	41	28
22'-1"									59	43	31	20	70	46	34	23
23'-1"													63	41	30	19
24'-1"													58	43	32	21

25 LB. DEAD LOAD - L/360 LIVE LOAD DEFLECTION																
Joist Clear Span	16" Depth				18" Depth				20" Depth							
	O.C. Spacing				O.C. Spacing				O.C. Spacing							
	12"	16"	19.2"	24"	12"	16"	19.2"	24"	12"	16"	19.2"	24"				
10'-1"	231	167	135	103	343	255	211	167	341	256	213	171				
11'-1"	202	145	117	89	314	233	193	152	313	235	196	156				
12'-1"	178	127	102	77	289	214	177	140	89	217	180	144				
13'-1"	159	113	90	67	268	198	164	129	268	201	168	134				
14'-1"	143	101	80	59	249	184	152	120	250	188	156	125				
15'-1"	135	95	75	55	233	172	142	112	235	176	147	116				
16'-1"	132	93	73	53	219	162	133	105	221	166	138	109				
17'-1"	159	113	90	67	206	152	125	98	209	156	130	102				
18'-1"	151	107	85	63	195	144	118	93	198	148	123	97				
19'-1"	118	82	64	47	184	136	112	88	188	141	116	91				
20'-1"	138	97	77	57	175	129	106	83	179	134	110	86				
21'-1"	111	77	60	43	167	123	101	79	171	128	105	82				
22'-1"	117	81	64	46	137	101	83	64	138	101	83	64				
23'-1"	94	70	59	42	131	97	79	61	132	97	79	61				
24'-1"	84	63	53	37	126	93	76	59	127	93	76	59				
25'-1"	73	55	46	32	121	89	72	56	121	89	72	56				
26'-1"	73	55	46	32	106	77	63	48	107	78	63	49				
27'-1"	65	49	41	29	102	74	60	46	103	75	61	47				
28'-1"	64	48	40	27	98	71	58	44	99	72	58	45				
29'-1"	56	42	35	23	77	57	46	35	95	69	56	43				
30'-1"					75	54	44	33	68	49	39	29				
31'-1"									66	47	38	28				

For S.I.: 1 inch = 25.4 mm; 1 lbf = 4.4 N; 1 psf = 47.9 Pa

- 1) Table is based on repetitive member use installed in a floor or roof system with minimum 5/8-inch-thick sheathing attached to the top flanges.
- 2) No increase for repetitive member use or duration of load allowed.
- 3) Allowable load values in the table shall be reduced if repetitive member conditions are not achieved (20 percent for 3x2 and 13 percent for 4x2).
- 4) Loads noted in the table are limited by live load deflection and total load deflection as noted in the table.
- 5) Manufactured length refers to overall length that includes the possibility of a 5 1/2-inch bearing on both ends. To calculate the allowable "clear span" subtract 11 inches from the tabulated manufactured length.



TABLE 1C (15DL-L/480) - ALLOWABLE UNIFORM FLOOR LIVE LOADS (psf)

Joist Clear Span	15 LB. DEAD LOAD - L/480 LIVE LOAD DEFLECTION															
	9 ¹ / ₄ " & 9 ³ / ₈ " Depth				11 ¹ / ₄ " Depth				11 ⁷ / ₈ " Depth				13" & 14" Depth			
	O.C. Spacing				O.C. Spacing				O.C. Spacing				O.C. Spacing			
	12"	16"	19.2"	24"	12"	16"	19.2"	24"	12"	16"	19.2"	24"	12"	16"	19.2"	24"
10'-1"	139	104	87	70	187	136	112	87	212	155	127	99	241	177	145	113
11'-1"	110	83	69	55	158	118	99	77	179	134	112	87	212	155	127	99
12'-1"	86	65	54	43	124	93	77	62	141	106	88	70	171	128	107	86
13'-1"	70	53	44	35	101	76	63	51	115	86	72	58	142	107	89	71
14'-1"	58	43	36	29	79	59	49	40	90	67	56	45	114	86	71	57
15'-1"	48	36	30	24	68	51	42	33	77	58	48	38	96	72	60	48
16'-1"	66	49	41	33	58	43	36	29	66	49	41	33	80	60	50	40
17'-1"	54	41	34	27	69	52	43	34	78	59	49	38	66	51	43	34
18'-1"	46	35	29	23	59	44	37	30	67	50	42	34	80	60	50	40
19'-1"	40	30	25	20	62	47	39	31	70	53	44	35	69	52	43	35
20'-1"					52	39	33	26	59	44	37	30	60	45	38	30
21'-1"					45	33	28	23	51	38	32	26	62	47	39	31
22'-1"									45	34	28	23	56	42	35	28
23'-1"													48	36	30	24
24'-1"													43	32	27	22

Joist Clear Span	15 LB. DEAD LOAD - L/480 LIVE LOAD DEFLECTION											
	16" Depth				18" Depth				20" Depth			
	O.C. Spacing				O.C. Spacing				O.C. Spacing			
	12"	16"	19.2"	24"	12"	16"	19.2"	24"	12"	16"	19.2"	24"
10'-1"	241	177	145	113	273	205	171	137	249	186	155	124
11'-1"	212	155	127	99	251	188	157	125	228	171	142	114
12'-1"	188	137	112	87	231	174	145	116	210	158	131	105
13'-1"	169	123	100	77	215	161	134	107	195	146	122	98
14'-1"	153	111	90	69	201	150	125	100	182	137	114	91
15'-1"	145	105	85	65	188	141	118	94	171	128	107	85
16'-1"	142	103	83	63	177	133	111	88	161	121	101	80
17'-1"	169	123	100	77	167	125	104	84	152	114	95	76
18'-1"	144	108	90	73	158	119	99	79	144	108	90	72
19'-1"	128	92	74	57	150	113	94	75	137	103	85	68
20'-1"	112	84	70	56	143	107	90	72	130	98	81	65
21'-1"	88	66	55	44	137	103	85	68	124	93	78	62
22'-1"	80	60	50	40	98	74	61	49	110	82	69	55
23'-1"	75	56	47	38	94	71	59	47	105	79	66	53
24'-1"	70	52	44	35	90	68	57	45	101	76	63	51
25'-1"	64	48	40	32	87	65	54	44	97	73	61	49
26'-1"	60	45	38	30	79	59	49	39	85	64	53	43
27'-1"	54	40	34	27	76	57	47	38	82	62	51	41
28'-1"	48	36	30	24	73	55	46	37	79	60	50	40
29'-1"	41	31	26	21	58	44	36	29	77	58	48	38
30'-1"					57	42	35	28	62	46	39	31
31'-1"									60	45	37	30

For S.I.: 1 inch = 25.4 mm; 1 lbf = 4.4 N; 1 psf = 47.9 Pa

- 1) Table is based on repetitive member use installed in a floor or roof system with minimum 5/8-inch sheathing attached to the top flanges.
- 2) No increase for repetitive member use or duration of load allowed.
- 3) Allowable load values in the table shall be reduced if repetitive member conditions are not met (20 percent for 3x2 and 13 percent for 4x2).
- 4) Loads noted in the table are limited by live load deflection and total load deflection noted.
- 5) Manufactured length refers to overall length that includes the possibility of a 5 1/2-inch bearing on both ends. To calculate the allowable "clear span" subtract 11 inches from the tabulated manufactured length.



TABLE 1D (25DL-L/480) - ALLOWABLE UNIFORM FLOOR LIVE LOADS (psf)

Joist Clear Span	25 LB. DEAD LOAD - L/480 LIVE LOAD DEFLECTION															
	9 ¹ / ₄ " & 9 ³ / ₈ " Depth				11 ¹ / ₄ " Depth				11 ⁷ / ₈ " Depth				13" & 14" Depth			
	O.C. Spacing				O.C. Spacing				O.C. Spacing				O.C. Spacing			
	12"	16"	19.2"	24"	12"	16"	19.2"	24"	12"	16"	19.2"	24"	12"	16"	19.2"	24"
10'-1"	139	104	87	70	178	128	103	78	202	145	117	89	231	167	135	103
11'-1"	110	83	69	55	157	112	90	68	178	127	102	77	202	145	117	89
12'-1"	86	65	54	43	124	93	77	57	141	106	87	65	171	127	102	77
13'-1"	70	53	44	35	101	76	63	48	115	86	72	55	142	107	89	67
14'-1"	58	43	36	29	79	59	49	40	90	67	56	45	114	86	70	51
15'-1"	48	36	30	24	68	51	42	33	77	58	48	38	96	72	60	47
16'-1"	66	49	41	33	58	43	36	29	66	49	41	33	80	60	50	35
17'-1"	54	41	34	27	69	52	40	27	78	55	41	28	68	51	41	28
18'-1"	46	35	29	23	59	43	33	22	67	49	37	25	80	60	46	32
19'-1"	40	30	25	20	62	47	39	29	70	53	42	29	69	52	39	27
20'-1"					52	39	33	26	59	44	37	28	60	45	34	23
21'-1"					45	33	28	22	51	38	32	25	62	47	39	28
22'-1"									45	34	28	20	56	42	34	23
23'-1"													48	36	30	19
24'-1"													43	32	27	21

Joist Clear Span	25 LB. DEAD LOAD - L/480 LIVE LOAD DEFLECTION											
	16" Depth				18" Depth				20" Depth			
	O.C. Spacing				O.C. Spacing				O.C. Spacing			
	12"	16"	19.2"	24"	12"	16"	19.2"	24"	12"	16"	19.2"	24"
10'-1"	231	167	135	103	273	205	171	137	249	186	155	124
11'-1"	202	145	117	89	251	188	157	125	228	171	142	114
12'-1"	178	127	102	77	231	174	145	116	210	158	131	105
13'-1"	159	113	90	67	215	161	134	107	195	146	122	98
14'-1"	143	101	80	59	201	150	125	100	182	137	114	91
15'-1"	135	95	75	55	188	141	118	94	171	128	107	85
16'-1"	132	93	73	53	177	133	111	88	161	121	101	80
17'-1"	159	113	90	67	167	125	104	84	152	114	95	76
18'-1"	139	103	85	63	158	119	99	79	144	108	90	72
19'-1"	118	82	64	47	150	113	94	75	137	103	85	68
20'-1"	112	84	70	56	143	107	90	72	130	98	81	65
21'-1"	88	66	55	43	137	103	85	68	124	93	78	62
22'-1"	80	60	50	40	98	74	61	49	110	82	69	55
23'-1"	75	56	47	38	94	71	59	47	105	79	66	53
24'-1"	70	52	44	35	90	68	57	45	101	76	63	51
25'-1"	64	48	40	32	87	65	54	44	97	73	61	49
26'-1"	60	45	38	30	79	59	49	39	85	64	53	43
27'-1"	54	40	34	27	76	57	47	38	82	62	51	41
28'-1"	48	36	30	24	73	55	46	37	79	60	50	40
29'-1"	41	31	26	21	58	44	36	29	77	58	48	38
30'-1"					57	42	35	28	62	46	39	29
31'-1"									60	45	37	28

For S.I.: 1 inch = 25.4 mm; 1 lbf = 4.4 N; 1 psf = 47.9 Pa

- 1) Table is based on repetitive member use installed in a floor or roof system with minimum 5/8-inch-thick sheathing attached to the top flanges.
- 2) No increase for repetitive member use or duration of load allowed.
- 3) Allowable load values in the table shall be reduced if repetitive member conditions are not achieved (20 percent for 3x2 and 13 percent for 4x2).
- 4) Loads noted in the table are limited by live load deflection and total load deflection as noted in the table.
- 5) Manufactured length refers to overall length that includes the possibility of a 5/2-inch bearing on both ends. To calculate the allowable "clear span" subtract 11 inches from the tabulated manufactured length.

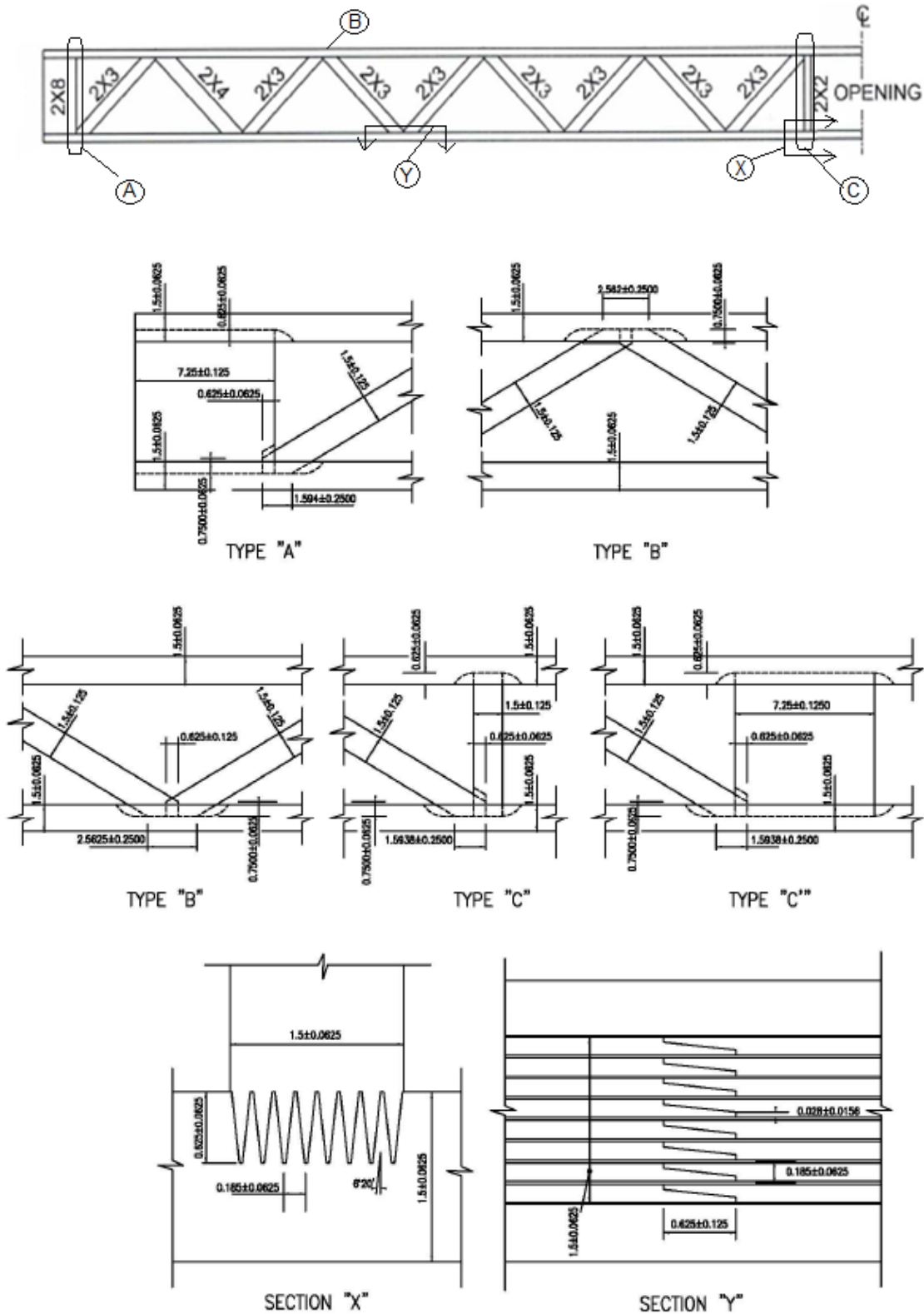

**FIGURE 2 – TYPICAL OPEN JOIST 2000 WOOD TRUSS AND DETAILS
(MEMBER SIZES VARY)**

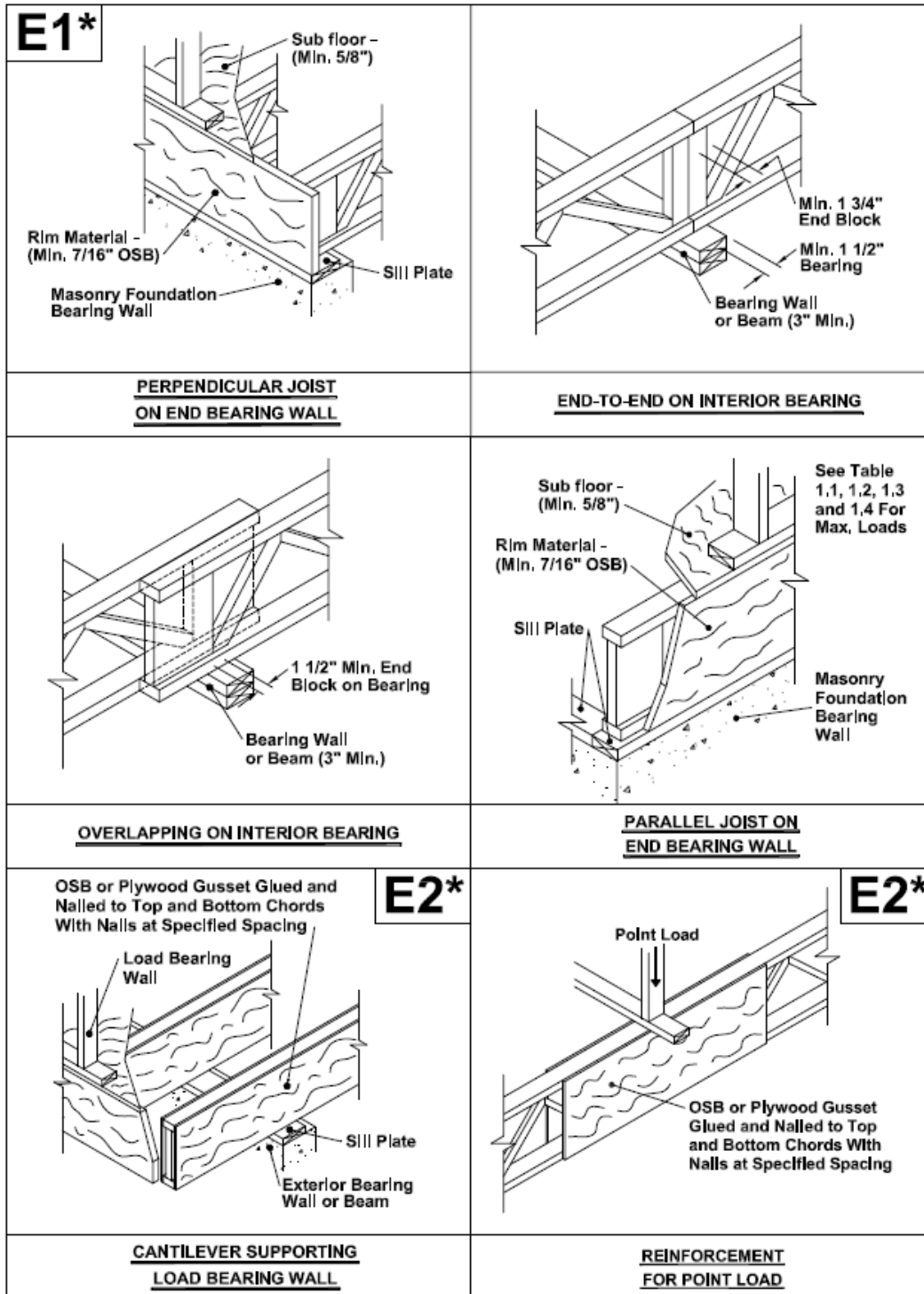

E1* = Engineering required to determine the thickness of rim material.
E2* = Engineering required to determine the length and thickness of gusset material.

FIGURE 3 – MOST COMMONLY USED DETAILS
 (See OJ 2000 Installation Instructions for more details)



FLORIDA SUPPLEMENT

**ALLEGHENY STRUCTURAL
COMPONENTS, INC.**
3778 Oneida Valley Road
Emlenton, Pennsylvania 16373
(724) 867-1100
AlleghenyStructural.com

OPEN JOIST 2000® WOOD TRUSSES

CSI Sections:

- 06 11 00 Wood Framing
- 06 11 13 Engineered Wood Products
- 06 17 00 Shop Fabricated Structural Wood
- 06 17 53 Shop-Fabricated Wood Trusses

1.0 RECOGNITION

Allegheny Structural Components, Inc., Open Joist 2000® wood trusses evaluated in IAPMO UES ER-501 are a satisfactory alternative to the following codes and regulations:

- 2023 Florida Building Code, Building (FBC, Building)
- 2023 Florida Building Code, Residential (FBC, Residential)

2.0 LIMITATIONS

Use of Open Joist 2000® wood trusses described in this report supplement is subject to the following limitations:

2.1 Use of Open Joist 2000® wood trusses shall comply with the provisions of the applicable codes, the manufacturer's published installation instructions, and this report. Where conflicts occur in these provisions, the most restrictive shall govern.

2.2 Evaluation to the high-velocity hurricane zone provisions in Chapter 23 of the FBC is outside the scope of this report.

2.3 For products falling under Section 5(d) of Florida Rule 61G20-3.008, it has been verified that the report holder's quality assurance program is audited by a quality assurance entity, approved by the Florida Building Commission, to provide oversight and determine that the products are being manufactured as described in this evaluation report to establish continual product performance.

2.4 This supplement expires concurrently with ER-501.

For additional information about this evaluation report please visit www.uniform-es.org or email us at info@uniform-es.org