



### EVALUATION SUBJECT: SIMPSON STRONG-TIE BOLT HOLD-DOWNS

**REPORT HOLDER:**  
SIMPSON STRONG-TIE COMPANY, INC.  
5956 West Las Positas Boulevard  
Pleasanton, California 94588  
(800) 925-5099  
[www.strongtie.com](http://www.strongtie.com)

CSI Division: 06-WOOD, PLASTICS, AND COMPOSITES

CSI Section: 06 05 23-Wood, Plastic, and Composite Fastenings

### 1.0 SCOPE OF EVALUATION

#### 1.1 Compliance to the following codes & regulations:

- 2021, 2018, 2015, 2012, and 2009 International Building Code® (IBC)
- 2021, 2018, 2015, 2012, and 2009 International Residential Code® (IRC)
- 2023 City of Los Angeles Building Code – attached Supplement
- 2023 City of Los Angeles Residential Code – attached Supplement

#### 1.2 Evaluated in accordance with:

- ICC-ES AC155, Acceptance Criteria for Hold-Downs (Tie-Downs) Attached to Wood Members

#### 1.3 Properties assessed:

- Structural

### 2.0 PRODUCT USE

Simpson Strong-Tie bolt hold-down connectors are used as wood framing anchorage, such as to connect wood posts to concrete foundations or to connect an upper-story wood post to a lower-story supporting wood post, according to 2021, 2018, and 2015 IBC Sections [2304.10.3](#) and [2305.1](#); 2012 and 2009 IBC Sections [2304.9.3](#), [2305.1](#), [2308.9.3.1](#), [2308.9.3.2](#); [ANSI/AWC SDPWS-2021](#) and [ANSI/AWC SDPWS-2015](#) Special Design Provisions for Wind and Seismic Sections 4.3.6.4.2 and 4.3.6.1.3; and [AFP&A SDPWS-2008](#) (2005) Special Design Provisions for Wind and Seismic Sections 4.3.6.4.2 and 4.3.6.1.2. As required by IBC Section [1604.8](#), the hold-down connectors are used as anchorage of concrete and masonry walls to structural wood elements to provide lateral support for the walls.

When regulated under the IRC, the hold-down connectors may also be used when the tabulated loads are equal to or exceed the load requirements in the IRC, when an engineered design is submitted in accordance with IRC Section [R301.1.3](#), or in alternative braced wall panels complying with 2021, 2018, 2015, or 2012 IRC Sections [R602.10.2.2.1](#), [R602.10.6.1](#), [R602.10.6.2](#) and [R602.10.7](#); 2009 IRC Sections [R502.2.2.3](#), [R602.10.1.4.1\(2\)](#), [R602.10.3.2](#), [R602.10.3.3](#), [R602.10.4.4](#), and [R602.10.5.3](#). In addition, the hold-down connectors may be used as anchorage of concrete and masonry walls to structural wood elements to provide lateral support for the walls in accordance with 2018 IRC Section [R606.12.2.3](#); 2015 IRC Sections [R606.12.2.3](#) and [R608.9.1](#); 2012 or 2009 IRC Sections [R606.12.2.3](#) and [R611.9.1](#).

### 3.0 PRODUCT DESCRIPTION

#### 3.1 Product Information

**3.1.1 HD Bolt Hold-downs:** The HD bolt hold-downs consist of a main structural steel component with pre-punched holes along their side for the installation of bolts used to connect the hold-down to the wood member. The hold-downs have a factory-welded load transfer plate at the base with a pre-punched hole for an anchor rod or bolt. HD12 and HD19 hold-downs have a tapered leg that extends below the base, which positions the first bolt in the wood member seven bolt diameters from the end of the wood member. HD12 and HD19 bodies are formed from No. 3 gage steel. The base plate component is manufactured from 3/8-inch-thick (9.5 mm) steel for the HD12 and HD19. [Figure 1](#), [Table 1](#), and [Table 3](#) of this report provide product dimensions, required fasteners, allowable loads, and displacements.

**3.1.2 HDB Bolt Hold-downs:** HD3B hold-down is a single-piece formed hold-down consisting of a steel strap with a four-ply formed seat element for an anchor bolt. The straight-strap portion of the hold-down has pre-punched bolt holes for the installation of bolts used to connect the hold-down to the wood member. HD3B is die-formed from No. 12 gage galvanized steel. HD5B, HD7B, and HD9B bolt hold-downs consist of a main structural steel component with pre-punched holes for the installation of bolt fasteners used to connect the hold-down to the wood member. HD5B and HD7B bodies are formed from No. 10 gage galvanized steel. Crossbars are steel bar stock 3/8-inch (9.5 mm) thick by 3/4-inch (19 mm) deep and the washers are formed from 3/16-inch-thick (9.5 mm) steel plates. The HD9B body is formed from No. 7 gage galvanized steel and its crossbars are 3/8 inch (9.5 mm) thick by 1 inch (25.4 mm) deep. The washer for HD9B is formed using a 3/8-inch (9.5 mm) thick steel plate. [Figure 2](#), [Table 2](#), and [Table 3](#) of this report provide product dimensions, required fasteners, allowable loads, and displacements.

The product described in this Uniform Evaluation Service (UES) Report has been evaluated as an alternative material, design or method of construction in order to satisfy and comply with the intent of the provision of the code, as noted in this report, and for at least equivalence to that prescribed in the code in quality, strength, effectiveness, fire resistance, durability and safety, as applicable, in accordance with IBC Section 104.11. This document shall only be reproduced in its entirety.

Copyright © 2024 by International Association of Plumbing and Mechanical Officials. All rights reserved. Printed in the United States. Ph: 1-877-4IESRPT • Fax: 909.472.4171  
web: [www.uniform-es.org](http://www.uniform-es.org) • 4755 East Philadelphia Street, Ontario, California 91761-2816 – USA





### 3.2 Material Information

**3.2.1 Steel:** HD12, HD19, and HD9B base plates are manufactured from steel complying with [ASTM A36](#) having a minimum yield strength of 36,000 psi (248 MPa) and minimum tensile strength of 58,000 psi (400 MPa). Base metal thicknesses for the bolt hold-downs in this report are as follows:

THICKNESS/ GAGE	BASE METAL THICKNESS (inches)
3/8 inch	0.3600
5/16 inch	0.2975
No. 3	0.2285
3/16 inch	0.1775
No. 7 (A653)	0.1715
No. 7 (A1011)	0.1705
No. 10	0.1275
No. 12	0.0975

For SI: 1 inch = 25.4 mm

Model numbers do not list the Z or HDG ending in this report, but the information shown is applicable. HD series bolt hold-downs have a painted finish and hot-dipped galvanizing is available. The HDB hold-downs are provided with hot-dipped galvanized finishes

The holder of this report (Simpson Strong-Tie Company) or the lumber treater shall be notified for recommendations on minimum corrosion resistance of steel connectors in contact with the specific proprietary preservative-treated or fire-retardant-treated lumber.

**3.2.2 Wood:** Wood members connected to hold-downs shall be either sawn lumber or engineered lumber. Sawn lumber shall have a minimum specific gravity of 0.50 and a maximum moisture content of 19 percent. Engineered lumber shall have a minimum equivalent specific gravity of 0.50 and a maximum moisture content of 16 percent. Minimum wood member thickness (depth) is specified in [Table 1](#) and [Table 2](#) of this report.

### 3.2.3 Fasteners

**3.2.3.1 Bolts:** Machine bolts shall comply with [ANSI/ASME Standard B18.2.1](#) and with [ASTM A307](#). The minimum bending yield strength ( $F_{yb}$ ) of the bolt shall be 45,000 psi (310 MPa).

**3.2.3.2 Threaded Anchor Rods:** As a minimum, threaded steel anchor rods shall comply with [ASTM F1554](#) Grade 36 or equivalent.

**3.2.3.3 Preservative-treated and Fire-retardant-treated Wood:** Fasteners used in contact with preservative-treated or fire-retardant-treated lumber shall comply with 2021, (2018), (2015) IBC Section [2304.10.5](#); 2012 (2009) IBC

Section [2304.9.5](#); and 2021, (2018), (2015), (2012) (2009) IRC Section [R317.3](#). The report holder (Simpson Strong-Tie Company) or lumber treater shall be notified for recommendations on minimum corrosion resistance and connection capacities of fasteners used with the specific proprietary preservative-treated or fire-retardant-treated lumber.

## 4.0 DESIGN AND INSTALLATION

### 4.1 Design

**4.1.1 Hold-Down Assembly:** As shown in [Table 1](#) and [Table 2](#) of this report, the allowable loads are for hold-down assemblies consisting of the following components: (1) hold-down device; (2) an anchor bolt/rod attached to the seat of the device; (3) a wood member having minimum specified dimensions and properties; (4) quantity and size of fasteners used to attach the hold-down device to the wood member; and, in one case as noted, (5) a standard cut washer (Type A plain steel washer (W)) with dimensions conforming to [ASME B18.22.1](#). As shown in the product tables of this report, the allowable loads are based on allowable stress design (ASD). The load values include the load duration factor ( $C_D$ ) corresponding with the applicable loads in accordance with the [ANSI/AWC NDS-2018](#), (2015) (2012) (2005) National Design Specification (NDS) for Wood Construction.

Where design load combinations include earthquake loads or effects, the story drifts of the structure shall be determined in accordance with Section 12.8.6 of [ASCE/SEI 7-16](#) with Supplement 1 (7-10) (7-05) except for those structures analyzed using the Simplified Design Procedure pursuant to Section 12.14. When using the basic load combinations in accordance with 2021 IBC Section [1605.1](#) (ASCE/SEI 7-16 Section 2.4), or 2018, 2015, 2012, or 2009 IBC Section [1605.3.1](#), the tabulated allowable loads for the hold-down (tie-down) shall not be increased for wind or earthquake loading. When using the alternative ASD basic load combinations in 2021 IBC Section [1605.2](#) or 2018, 2015, 2012, or 2009 IBC Section [1605.3.2](#) that include wind or earthquake loads, the tabulated allowable loads for the hold-down (tie-down) shall not be increased by 33 $\frac{1}{3}$  percent, nor shall the alternative basic load combinations be reduced by a factor of 0.75.

Deflection of a shear wall restrained from overturning by hold-downs installed in accordance with this report shall be determined in accordance with 2021, 2018, 2015, or 2012 IBC Section [2305.3](#); 2009 IBC Section [2305.1](#).

Total deflection values  $\Delta_{all}$  and  $\Delta_s$  at ASD-level and strength-level forces, respectively, for hold-down assemblies shown in [Tables 1](#) and [Table 2](#) of this report, include all sources of hold-down device rotation and extension and anchor rod elongation where the length of the anchor rod is a maximum of 6 inches (152 mm) for the HDB hold-down and a maximum of 8 inches (203 mm) for the HD series



hold-downs. The addition of the hold-down anchor rod elongation to the total elongation (deflection) of the hold-down assembly needs to be evaluated when the actual diameter, length, or ASTM steel specification of the anchor rod differs from that shown in this report. When hold-downs are used in series, the cumulative deformation of all hold-downs within that series should be accounted for.

Symbol  $\Delta_s$ , as used in this report, refers to the symbol  $d_a$  in 2021, (2018), (2015), (2012) (2009) IBC Section [2305.3.2](#) and the symbol  $\Delta_a$  in [2021 ANSI/AF&PA SDPWS](#) Section 4.3.4 and 2015 (2008) (2005) [ANSI/AF&PA SDPWS](#) Section 4.3.2.

Tabulated allowable loads are for hold-downs connected to wood used under continuously dry interior conditions and where sustained temperatures are 100°F (37.8°C) or less. Allowable loads shown in [Table 1](#) and [Table 2](#) of this report shall be adjusted by the wet service factor ( $C_m$ ) specified in the ANSI/AWC NDS when hold-downs are fastened to wood having a moisture content greater than 19 percent (16 percent for engineered lumber), or where wet service is anticipated.

Allowable loads shown in [Table 1](#) and [Table 2](#) in this report shall be adjusted by the temperature factor ( $C_t$ ) specified in the ANSI/AWC NDS when hold-downs are fastened to wood that will experience sustained exposure to temperatures, exceeding 100°F (37.8°C).

The design of wood members fastened to bolt hold-down devices shall consider combined stresses due to axial tension and flexural bending induced by eccentricity in the connection. Stresses shall be evaluated at the critical net section and shall consider combined flexural bending due to hold-down (tie-down) eccentricity relative to the centroid of the connected wood member ( $M_{xx}$  and  $M_{yy}$ ), and tension (T).

**4.1.2 Hold-Down Devices Used as Anchorage of Structural Walls:** Allowable steel strengths are detailed in [Table 3](#) of this report for the HDB and HD hold-down devices. Values are for the steel anchorage device independent of the bolts used to attach the hold-down to the wood member and anchor rod. Values are used when designing structural wall anchorage in accordance with Sections 12.10 and 12.11.2 of ASCE/SEI 7.

Hold-down assembly strengths in [Table 1](#) and [Table 2](#) of this report may be used for wall anchorage in accordance with 2021, (2018), (2015), IRC Sections [R606.12.2.3](#) and [R608.9.1](#); 2012 (2009) IRC Sections [R606.12.2.3](#) and [R611.9.1](#).

**4.1.3 Anchorage to Concrete or Masonry:** Adequate embedment length and anchorage details, including edge and end distances shall be determined in accordance with [Chapters 19](#) or [21](#) of the IBC as applicable, for the design of anchorage to concrete and masonry structural members except for those structures designed in accordance with the IRC or the conventional light-frame construction provisions

of Section [2308](#) of the IBC. Where anchors are designed to resist seismic loads, the seismic load effects shall include overstrength in accordance with ASCE/SEI 7-10 with Supplement 1 or ASCE/SEI 7-16 with Supplement 1.

**4.2 Installation:** Installation of the Simpson Strong-Tie hold-down connectors shall be in accordance with the manufacturer's published installation instructions and this evaluation report. Where a conflict exists between this report and the manufacturer's published installation instructions, the more restrictive shall prevail.

### 4.3 Special Inspection

**4.3.1** A statement of special inspection shall be prepared by the registered design professional in responsible charge and submitted to the building official for approval when required by 2021, 2018, 2015, or 2012 IBC Section [1704.3](#) or 2009 IBC Section [1705](#). A statement of responsibility shall be submitted to the building official for approval when required by 2021, 2018, 2015, or 2012 IBC Section [1704.4](#); or 2009 IBC Section [1709](#) as applicable.

**4.3.2** Periodic special inspection shall be conducted when the HDB or HD series hold-downs are components within the main wind-force-resisting system of structures constructed in areas listed in 2021, 2018 IBC Section [1705.11](#); 2015 IBC Section [1705.11](#); 2012 IBC Section [1705.10](#); 2009 IBC Section [1706.1](#). Special inspection requirements do not apply to structures, or portions thereof, that qualify for an exception according to 2018 IBC Sections [1704.2](#), [1705.3](#), or [1705.11.1](#); 2015 IBC Sections [1704.2](#), [1705.3](#), or [1705.11.1](#); 2012 IBC Sections [1704.2](#), [1705.3](#), or [1705.10.1](#); 2009 IBC Sections [1704.1](#), [1704.4](#), [1706.2](#), or [1706.3](#).

**4.3.3** Periodic special inspection for seismic resistance shall be conducted in accordance with 2021, 2018 IBC Section [1705.12](#); 2015 IBC Section [1705.12](#); 2012 IBC Section [1705.11](#); or 2009 Section [1707](#) where required. Special inspection requirements for seismic resistance do not apply to structures, or portions thereof, that qualify for an exception pursuant to 2021, 2018 IBC Sections [1704.2](#), [1705.12](#), or [1705.12.2](#); 2015 IBC Sections [1704.2](#), [1705.12](#), or [1705.12.2](#); 2012 IBC Sections [1704.2](#), [1705.11](#), or [1705.11.2](#); or 2009 IBC Sections [1704.1](#), [1705.3](#), [1707.3](#), or [1707.4](#).

**4.3.4** For installations under the IRC, special inspection is not normally required. However, when an engineered design is submitted or required according to IRC Section R301.1.3, periodic special inspection requirements and exemptions are as stated in Sections 4.3.1, 4.3.2, and 4.3.3 of this report as applicable.

### 5.0 LIMITATIONS

Simpson Strong-Tie bolt hold-down connectors detailed in this report comply with or are acceptable alternatives to what is specified in the codes and regulations listed in Section [1.0](#) of this report subject to the following limitations:



**5.1** Hold-downs shall be manufactured, identified, and installed in concurrence with the manufacturer's published installation instructions and this report. Where conflicts occur, the more restrictive governs. During installation, a copy of the instructions shall be available at the job site at all times.

**5.2** Calculations, drawings, and details shall be submitted to the building official showing compliance with this report. A registered design professional shall prepare the calculations where required by the statutes of the jurisdiction in which the project is to be constructed.

**5.3** Adjustment factors shall be considered, where applicable, as noted in Section 4.1 of this report and the applicable codes. No further duration of load increase for wind or earthquake loading shall be allowed.

**5.4** Connected wood members and fasteners shall comply, respectively, with Sections 3.2.2 and 3.2.3 of this report.

**5.5** Use of hold-down connectors with fire-retardant-treated or preservative-treated lumber shall be in accordance with Section 3.2.1 of this report. Use of fasteners with fire-retardant-treated or preservative-treated lumber shall be in accordance with Section 3.2.3.3 of this report. All such uses are subject to the approval of the building official, since the effects of corrosion of metal in contact with chemically treated wood on the structural performance of the devices are outside the scope of this report.

**5.6** Anchorage to masonry structural members or concrete shall be provided in accordance with Section 4.1.3 of this report.

**5.7** Special inspections for the hold-downs shall be provided in accordance with Section 4.3 of this report.

**5.8** Special inspections for anchor bolts in concrete or masonry shall be conducted in accordance with Sections 1705.3 or 1705.4 of the 2021, 2018, 2015, and 2012 IBC; or Sections 1704.4 or 1704.5 of the 2009 IBC.

## 6.0 SUBSTANTIATING DATA

Data in accordance with ICC-ES Acceptance Criteria for Hold-Downs (Tie-Downs) Attached to Wood Members (AC155), Approved May 2015, editorially revised December 2020, inclusive of tests and calculations. Test reports are from laboratories in compliance with [ISO/IEC 17025](https://www.iso.org/standard/68549.html).

## 7.0 IDENTIFICATION

Products described in this report are identified with a die-stamped label indicating the name of the manufacturer (Simpson Strong-Tie), the model number, and the number of the index evaluation report (ER-102) that identifies products recognized in this report. Either IAPMO UES Mark of Conformity as shown below may also be used:

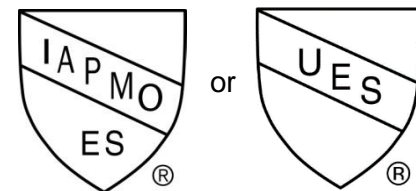

**IAPMO UES ER-143**

For additional information about this evaluation report please visit [www.uniform-es.org](http://www.uniform-es.org) or email at [info@uniform-es.org](mailto:info@uniform-es.org)



**TABLE 1 — ALLOWABLE TENSION LOADS AND DISPLACEMENTS FOR HD BOLT HOLD-DOWN ASSEMBLIES <sup>1,2,3</sup>**

MODEL NO.	DIMENSIONS (in.)							FASTENERS			MINIMUM WOOD MEMBER THK <sup>10</sup> (in.)	ALLOWABLE TENSION LOADS <sup>4</sup> , P <sub>all</sub> (lbs) C <sub>D</sub> =1.6	DISPLACEMENT <sup>5,6</sup> Δ, (in.)	
	HB <sup>9</sup>	SB	W	H	B	SO	CL	ANCHOR BOLT DIA. (in.)	WOOD MBR BOLTS <sup>8</sup>				Δ <sub>all</sub>	Δ <sub>s</sub>
									QTY.	DIA. (in.)				
HD12 <sup>7</sup>	7	4	3½	20 <sup>5</sup> / <sub>16</sub>	4¼	3⅝	2⅛	1	4	1	3½	11,350	0.171	0.244
											4½	12,665	0.171	0.250
											5½ <sup>11</sup>	14,220	0.162	0.250
	1⅞	4	1	4½	13,335	0.177	0.250							
				7¼	15,435	0.194	0.250							
				5½ <sup>11</sup>	15,510	0.162	0.227							
HD19 <sup>7</sup>	7	4	3½	24½	4¼	3⅝	2⅛	1⅞	5	1	7¼	16,735	0.191	0.250
											5½ <sup>11</sup>	16,775	0.200	0.250
								1¼	5	1	7¼	19,360	0.180	0.249
											5½ <sup>11</sup>	18,550	0.133	0.198
											5½ <sup>12</sup>	19,070	0.137	0.207

SI: 1 inch = 25.4 mm, 1 lbs = 4.45 N.

1. Tabulated allowable loads are for a hold-down assembly consisting of the hold-down device attached to a wood structural member(s) with the fasteners as specified in this table (Table 1 of this report).
2. Allowable loads for the hold-down assemblies are based on allowable stress design (ASD) and include the load duration factor, C<sub>D</sub> = 1.6, corresponding with wind/earthquake loading in accordance with the NDS. No further increase is allowed. The tabulated values shall be reduced where other load durations govern.
3. Anchorage to concrete or masonry shall be determined in accordance with Section 4.1.3 of this report. Anchorage to concrete or masonry walls shall be in accordance with Section 4.1.2 of this report.
4. Tabulated allowable (ASD) tension loads shall be multiplied by 1.4 to obtain the strength-level resistance loads related to the tabulated Δ<sub>s</sub> deformations.
5. Tabulated displacement values, Δ<sub>all</sub> and Δ<sub>s</sub>, for hold-down assemblies include all sources of hold-down assembly elongation, such as hold-down device extension and rotation fastener slip, and anchor rod elongation, at ASD-level and strength level forces respectively.
6. Elongation of the hold-down anchor rod shall be calculated when the actual unbraced length is greater than 8 inches for the HD series hold-downs, or the ASTM steel specification of the anchor rod differs from that described in Section 3.2.3 of this report. In lieu of calculating the elongation of the hold-down anchor rod for hold-downs raised 6 inches to 18 inches above the concrete for the HD2A and 8 inches to 18 inches for the HD series, it is permitted to add an additional anchor rod elongation of 0.01 to the tabulated hold-down deflection.
7. HD12 and HD19 require a standard cut washer, conforming to Section 4.1.1 of this report, to be installed between the anchor bolt nut and the seat of the hold-down when a 1⅞ inch diameter anchor bolt is used.
8. Hold-down bolts attaching the hold-down to the wood member shall be in accordance with Section 3.2.3.1 of this report and they each shall have a minimum of a standard cut washer installed between the wood post and the nut.
9. HB is the required minimum distance from the end of the post to the center of the first post bolt hole. The end distance may be increased as necessary for installation. Tension values are valid for hold-downs installed flush to, or raised off of, the sill plate provided that the minimum HB distance is maintained.
10. Wood structural member(s) shall have a minimum width of 3½ inches and be a minimum Grade No. 2 with a specific gravity of 0.50 to satisfy NDS Appendix E for tension loading, unless otherwise noted.
11. Wood structural member(s) shall have a minimum width of 5½ inches and be a minimum Grade No. 2 with a specific gravity of 0.50 to satisfy NDS Appendix E for tension loading.
12. Wood structural member(s) shall have a minimum width of 5½ inches and be a minimum Grade No. 1 with a specific gravity of 0.50 to satisfy NDS Appendix E for tension loading.

**FIGURE 1 –HD BOLT HOLD-DOWNS**

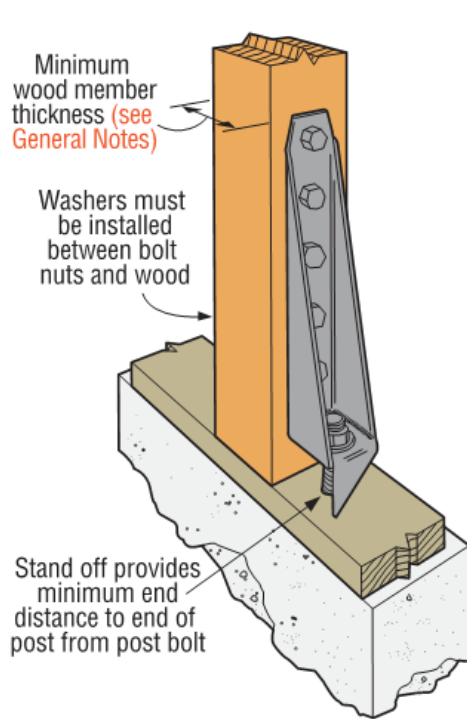

**HD19 Vertical Typical Installation**  
*(HD12 Similar)*

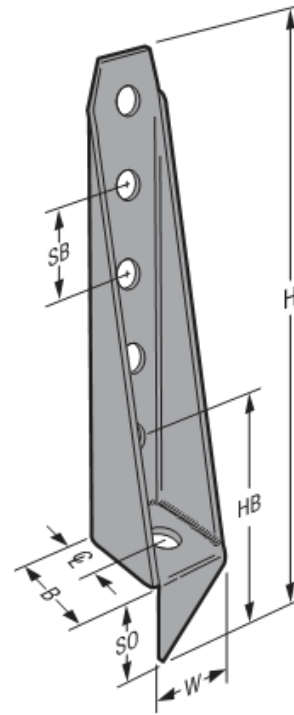

**HD19**  
**HD12 Similar**



**TABLE 2 — ALLOWABLE TENSION LOADS AND DISPLACEMENTS FOR HDB BOLT HOLD-DOWN ASSEMBLIES <sup>1,2</sup>**

MODEL NO.	DIMENSIONS (in.)							FASTENERS			MINIMUM WOOD MEMBER THK <sup>8</sup> (in.)	ALLOWABLE TENSION LOADS <sup>3</sup> P <sub>all</sub> (lbs.) C <sub>D</sub> =1.6	DISPLACEMENT <sup>4,5</sup> Δ, (in.)	
	HB	SB	W	H	B	SO	CL	ANCHOR BOLT DIA (in.)	WOOD MEMBER BOLTS				Δ <sub>all</sub>	Δ <sub>s</sub>
									QTY.	DIA. (in.)				
HD3B	4 <sup>7</sup> / <sub>8</sub>	2 <sup>1</sup> / <sub>2</sub>	2 <sup>1</sup> / <sub>2</sub>	8 <sup>5</sup> / <sub>8</sub>	2 <sup>1</sup> / <sub>4</sub>	3 <sup>3</sup> / <sub>8</sub>	1 <sup>1</sup> / <sub>2</sub>	5 <sup>8</sup> / <sub>16</sub>	2	5 <sup>8</sup> / <sub>16</sub>	1 <sup>1</sup> / <sub>2</sub>	1,895	0.156	0.207
											2 <sup>1</sup> / <sub>2</sub>	2,525	0.169	0.250
											3	3,130	0.120	0.239
HD5B	5 <sup>1</sup> / <sub>4</sub>	3	2 <sup>1</sup> / <sub>2</sub>	9 <sup>3</sup> / <sub>8</sub>	2 <sup>1</sup> / <sub>2</sub>	2	1 <sup>1</sup> / <sub>4</sub>	5 <sup>8</sup> / <sub>16</sub>	2	3 <sup>4</sup> / <sub>8</sub>	2 <sup>1</sup> / <sub>2</sub>	3,750	0.129	0.181
											3	4,505	0.156	0.223
											3 <sup>1</sup> / <sub>2</sub>	4,935	0.150	0.202
HD7B	5 <sup>1</sup> / <sub>4</sub>	3	2 <sup>1</sup> / <sub>2</sub>	12 <sup>3</sup> / <sub>8</sub>	2 <sup>1</sup> / <sub>2</sub>	2	1 <sup>1</sup> / <sub>4</sub>	7 <sup>8</sup> / <sub>16</sub>	3	3 <sup>4</sup> / <sub>8</sub>	3	6,645	0.142	0.198
											3 <sup>1</sup> / <sub>2</sub>	7,310	0.154	0.238
HD9B	6 <sup>1</sup> / <sub>8</sub>	3 <sup>1</sup> / <sub>2</sub>	2 <sup>7</sup> / <sub>8</sub>	14	2 <sup>1</sup> / <sub>2</sub>	2 <sup>3</sup> / <sub>8</sub>	1 <sup>1</sup> / <sub>4</sub>	7 <sup>8</sup> / <sub>16</sub>	3	7 <sup>8</sup> / <sub>16</sub>	3 <sup>1</sup> / <sub>2</sub>	7,740	0.159	0.250
											4 <sup>1</sup> / <sub>2</sub>	9,920	0.178	0.238
											7 <sup>1</sup> / <sub>4</sub>	10,035	0.179	0.241

SI: 1 inch = 25.4 mm, 1 lbs = 4.45 N.

1. Allowable loads for the hold-down assemblies are based on allowable stress design (ASD) and include the load duration factor, C<sub>D</sub> = 1.6, corresponding with wind/earthquake loading in accordance with the NDS. No further increase is allowed. Tabulated loads may be reduced where other load durations govern.
2. Anchorage to concrete or masonry shall be determined in accordance with Section 4.1.3 of this report. Anchorage to concrete or masonry walls shall be in accordance with Section 4.1.2 of this report.
3. Tabulated allowable (ASD) tension loads shall be multiplied by 1.4 to obtain the strength-level resistance loads associated with the tabulated Δ<sub>s</sub> deformations.
4. Tabulated displacement values, Δ<sub>all</sub> and Δ<sub>s</sub>, for hold-down assemblies include all sources of hold-down assembly elongation, such as fastener slip, hold-down device extension and rotation, and 6 inches of anchor rod elongation, at ASD-level and strength level forces respectively.
5. Elongation of the hold-down anchor rod shall be calculated when the actual unbraced length is greater than 6 inches, or the ASTM steel specification of the anchor rod differs from that described in Section 3.2.3 of this report. In lieu of calculating the elongation of the hold-down anchor rod for hold-downs raised 6 inches to 18 inches above the concrete, it is permitted to add an additional anchor rod elongation of 0.01 inch to the tabulated hold-down deflection.
6. Hold-down bolts attaching the hold-down to the wood member shall be in accordance with Section 3.2.3.1 of this report and each shall have a minimum of a standard cut washer installed between the wood post and the nut.
7. Allowable Tension loads are valid for hold-downs installed flush to, or raised off of, the sill plate.
8. Wood structural member(s) shall have a minimum width of 3<sup>1</sup>/<sub>2</sub> inches wide and be a minimum Grade No. 2 with a specific gravity of 0.50.

**FIGURE 2 – HDB BOLT HOLD-DOWNS**

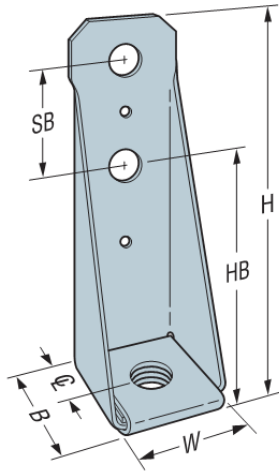

**HD3B**

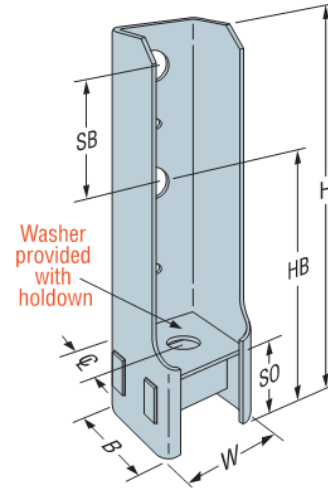

**HD5B**  
*(HD7B, HD9B Similar)*

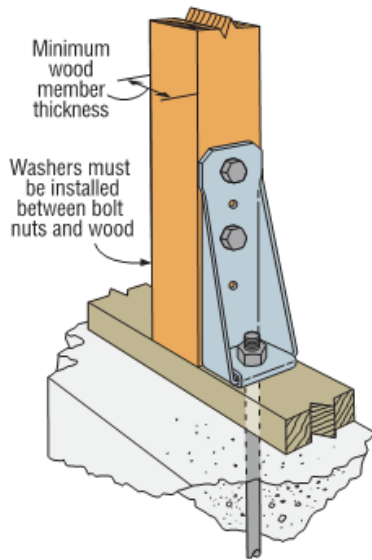

**HD3B**  
**Vertical Installation**

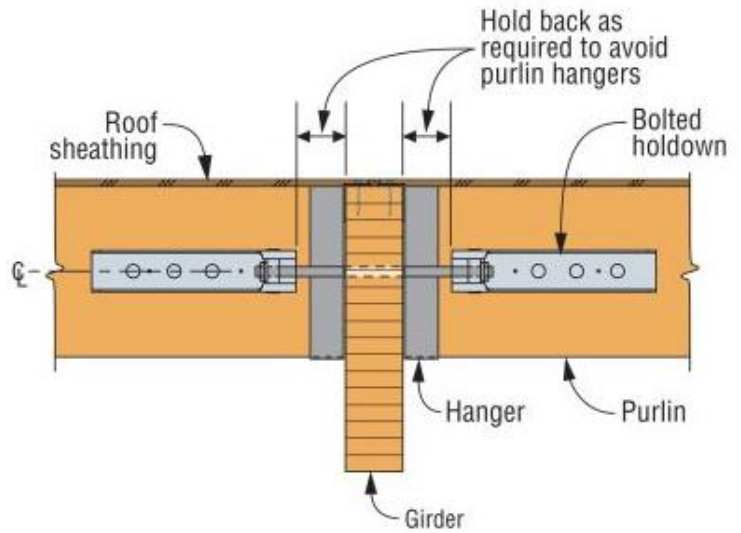

**HD7B Horizontal**  
**Purlin Installation**





**TABLE 3 — ALLOWABLE STEEL STRENGTH FOR HDB, AND HD BOLT HOLD-DOWN CONNECTORS<sup>1</sup>**

MODEL NO.	ASD STEEL STRENGTH (lbs.)
HD3B	3,940
HD5B	6,700
HD7B	8,330
HD9B	11,290
HD12	15,510
HD19 <sup>2</sup> (1 <sup>1</sup> / <sub>8</sub> " A.B)	21,965
HD19 (1 <sup>1</sup> / <sub>4</sub> " A.B)	23,630

SI: 1 inch = 25.4 mm, 1 lbs = 4.45 N.

- <sup>1</sup>. Steel strengths are provided when designing per Section 12.10 and 12.11.2 of [ASCE/SEI 7](#).
- <sup>2</sup>. HD19 requires a standard cut washer, conforming to Section [4.1.1](#) of this report, to be installed between the anchor bolt nut and seat of hold-down when a 1<sup>1</sup>/<sub>4</sub> inch diameter anchor bolt is used.



## CITY OF LOS ANGELES SUPPLEMENT

**SIMPSON STRONG-TIE COMPANY, INC.**  
5956 West Las Positas Boulevard  
Pleasanton, California 94588  
(800) 925-5099  
[www.strongtie.com](http://www.strongtie.com)

## SIMPSON STRONG-TIE BOLT HOLD-DOWNS

CSI Division: 06-WOOD, PLASTICS, AND  
COMPOSITES

CSI Section: 06 05 23-Wood, Plastic, and Composite  
Fastenings

### 1.0 RECOGNITION

Simpson Strong-Tie Bolt Hold-Downs evaluated in IAPMO UES ER-143 are acceptable alternatives to what is specified in the following codes and regulations:

- 2023 City of Los Angeles Building Code (LABC)
- 2023 City of Los Angeles Residential Code (LARC)

### 2.0 LIMITATIONS

**2.1** References in IAPMO UES ER-143 to section numbers of the 2023 IBC and 2023 IRC are the same section numbers in the LABC and LARC, as applicable.

**2.2** Hold-down connectors designed to resist shear wall overturning moments shall be reduced to 75 percent of the allowable load values shown in Tables 1 and 2 of ER-143, in accordance with LABC Section 2305.5.

**2.3** Engineered designs submitted in accordance with LARC Section R301.1.3 shall also comply with LARC Section R301.1.3.1.

**2.4** The design, installation, and inspection shall be in accordance with LABC Chapters 16 and 17, as applicable, due to local amendments to these chapters.

**2.5** The use as a flexible horizontal diaphragm to rigid wall anchor connectors is outside the scope of the supplement.

**2.6** The calculations shall be prepared, stamped, and signed by a California registered design professional.

**2.7** This supplement expires concurrently with ER-143.

For additional information about this evaluation report please visit [www.uniform-es.org](http://www.uniform-es.org) or email at [info@uniform-es.org](mailto:info@uniform-es.org)



## FLORIDA SUPPLEMENT

### EVALUATION SUBJECT: SIMPSON STRONG-TIE BOLT HOLD-DOWNS

**REPORT HOLDER:**  
**SIMPSON STRONG-TIE COMPANY, INC.**  
5956 West Las Positas Boulevard  
Pleasanton, California 94588  
(800) 925-5099  
[www.strongtie.com](http://www.strongtie.com)

**CSI Division: 06-WOOD, PLASTICS, AND COMPOSITES**

**CSI Section: 06 05 23-Wood, Plastic, and Composite Fastenings**

### 1.0 RECOGNITION

Simpson Strong-Tie bolt hold-down connectors have been evaluated for structural performance properties, subject to the requirements in ER-143 and this supplemental report for compliance with the following codes and regulations:

- 2023 Florida Building Code, Building, 8<sup>th</sup> Edition, (FBC–Building)
- 2023 Florida Building Code, Residential, 8<sup>th</sup> Edition, (FBC–Residential)

### 2.0 LIMITATIONS

Simpson Strong-Tie bolt hold-down connectors described in IAPMO UES ER-143 complies with the FBC–Building and the FBC–Residential, subject to the following limitations:

**2.1** The design and installation of the Simpson Strong-Tie® bolt hold-down connectors shall be in accordance with the 2021 International Building Code and the 2021 International Residential Code as noted in ER-143.

**2.2** Load combinations shall be in accordance with Sections 1605.1 or 1605.2 of the FBCBuilding, as applicable.

**2.3** Design wind loads shall be in accordance with Section 1609.1.1 of the FBC–Building or Section R301.2.1.1 of the FBC–Residential, as applicable, and Section 1620 of the FBC–Building where used in High-velocity Hurricane Zones (HVHZ)

**2.4** The use of Simpson Strong-Tie® bolt hold-down connectors recognized in this report complies with the High-velocity Hurricane Zone (HVHZ) provisions set forth in Sections 2122.7 of the FBC–Building. Where used in accordance with Section 2122.7.2 of FBC–Building, the connectors shall be designed to provide a positive direct connection to resist the horizontal forces as required in Section 1620 (HVHZ) of the FBC–Building or 200 pounds per lineal foot (2919 N/m), whichever is greater, in accordance with FBC–Building Section 2122.7.3.

**2.5** The use of Simpson Strong-Tie® bolt hold-down connectors recognized in this supplement complies with the High-velocity Hurricane Zone (HVHZ) provisions set forth in Sections 2324.2 of the FBC–Building. Where used in accordance with Section 2321.6 of FBC–Building, the structural angles, clips, and ties shall be designed to resist the uplift forces as required in Section 1620 (HVHZ) of the FBC–Building or 700 pounds (3114 N), whichever is greater, in accordance with FBC–Building Section 2321.7.

**2.6** Simpson Strong-Tie bolt hold-down connectors shall be manufactured, identified, and installed in accordance with ER-143 and the manufacturer’s published installation instructions. A copy of the installation instructions shall be available at the job site continuously during installation. If there is a conflict between this report and the manufacturer’s published installation instructions, the more restrictive prevails.

**2.7** For products falling under Section 5(d) of Florida Rule 61G20-3.008 verification that the report holder’s quality assurance program is audited by a quality assurance entity approved by the Florida Building Commission (or the building official when the report holder does not possess an approval by the Commission), to provide oversight and determine that the products are being manufactured as described in this evaluation report to establish continual product performance is required.

**2.8** This supplement expires concurrently with ER-143.

For additional information about this evaluation report please visit [www.uniform-es.org](http://www.uniform-es.org) or email us at [info@uniform-es.org](mailto:info@uniform-es.org)